

16596



***Call Us First!
DO NOT RETURN TO STORE.***

**For immediate help with assembly or product information
call our toll free number:**

1-800-577-9663

or email:

customerservice@backyardproductsllc.com

Our staff is ready to provide assistance

April through October M-F 8:00 AM to 4:30 PM EST

Saturday 8:30 AM to 4:30 PM EST

November through March M - F 8:00 AM to 5:00 PM EST

(This page intentionally left blank.)

VALUE SERIES

BELMONT 8' x 8' (244 x 244 cm)

ACTUAL FLOOR SIZE IS: 96 x 92-1/2" (243,8 x 235 cm)

KEEP THIS MANUAL FOR FUTURE REFERENCE

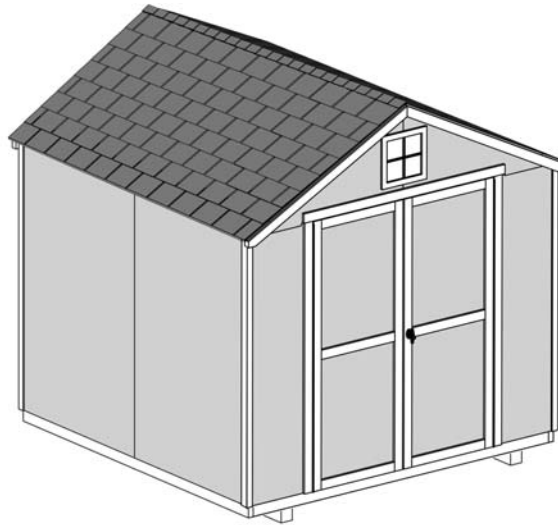

⚠ IMPORTANT! ⚠

READ INSTRUCTIONS THOROUGHLY PRIOR TO BEGINNING ASSEMBLY.

BEFORE YOU BEGIN

• **BUILDING RESTRICTIONS AND APPROVALS**

Be sure to check with local building department and homeowners association for specific restrictions and/ or requirements before building.

• **ENGINEERED DRAWINGS**

Contact our Customer Service Team if engineered drawings are needed to pull local permits.

• **SURFACE PREPARATION**

To ensure proper assembly you must build your shed on a level surface. Recommended methods and materials to level your shed are listed on page 7.

• **CHECK ALL PARTS**

Inventory all parts listed on pages 5 - 6. Contact our Customer Service Team if any parts are missing or damaged.

• **ADDITIONAL MATERIALS**

You will need additional materials to complete your shed. See page 4 for required and optional materials and quantities.



- CUSTOMER SERVICE -



Call: 1-800-577-9663 email: customerservice@backyardproductsllc.com

TOOLS

Required

Phillips Screwdriver 

Drill / Driver 

- 5/16" Drill Bit
- 1/8" Drill Bit
- #2 Philips Drive Bit

Level 

Pencil 

Tape Measure 

Square  or 

Utility Knife 

Shingle Blades 

Caulk Gun 

Paint Tools 

Safety Glasses 

Ladder 

Optional

Tool Belt/ Nail Pouch 

Tin Snips (for drip edge) 

Chalk Line 

Nail Gun
• gun nails 

Gloves 

Hammer 

Wood Glue 

Safety! Always use approved safety glasses during assembly.

HELPFUL REMINDER SYMBOLS

Look for these symbols for helpful reminders throughout this manual.



= Assistance Required; two or more people.



= Ensure squareness.



= Important required step or operation.



= Helpful assembly hint.



= Mark part with pencil.



BEGIN = Beginning of steps for assembly or installation.



FINISH = You have finished the assembly or installation.



= Level

ORIENT LUMBER AND TRIM FOR BEST APPEARANCE

Framing lumber is graded for structural strength and not appearance. Exterior trim is graded for one good side.

Always install the material leaving the best edge and best surface visible. Please remember that these blemishes in no way negatively affect the strength or integrity of our product. (See Fig. A, B, C.)

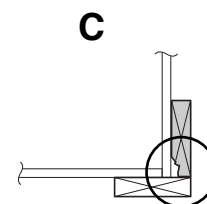
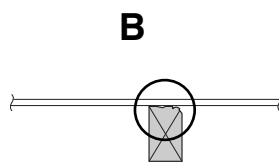
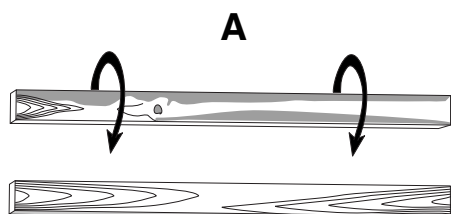

CONCRETE FOUNDATION

If you choose to install your kit on a concrete slab refer to the diagram below.

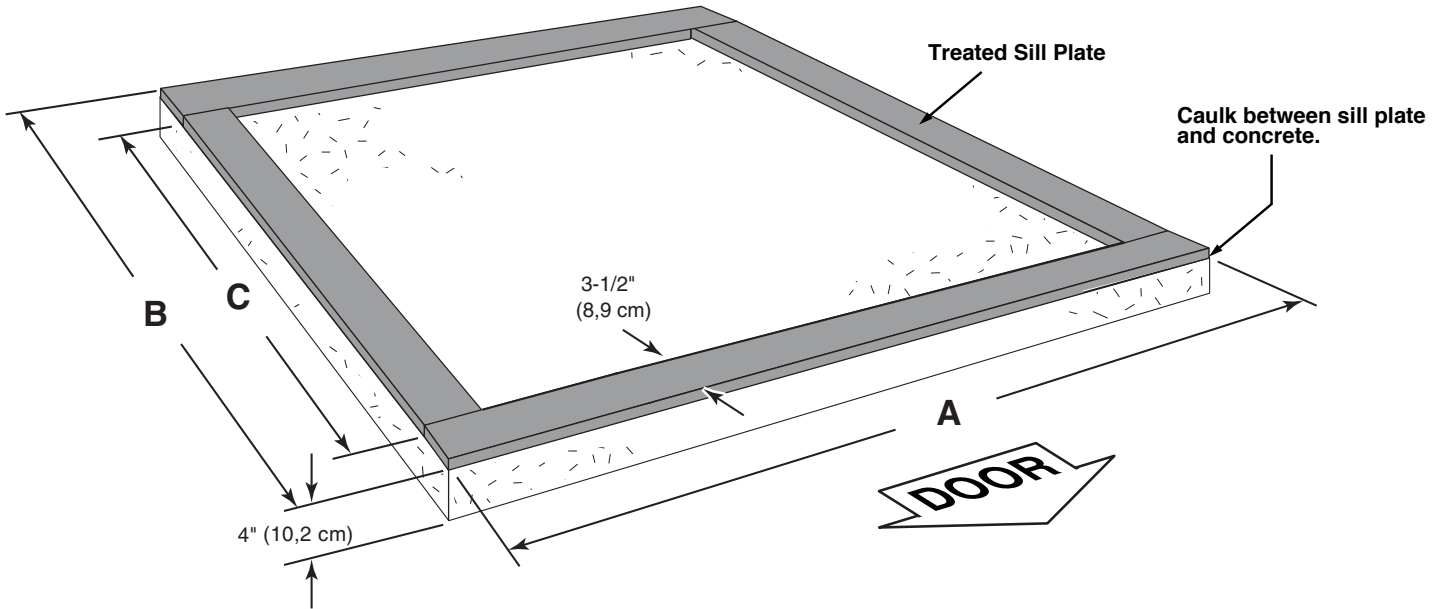

Building Size	Actual Floor Size	A	B	C
8'x 8' (243,8 x 243,8 cm)	8'x 7'-8-1/2" (243,8 x 235 cm)	96" (243,8 cm)	92-1/2" (235 cm)	85-1/2" (217,2 cm)

Requires:

x4 2 x 4 x 8' (5,1 x 10,2 x 243,8 cm) **MUST be treated lumber.**

x1 **Caulk**

Allow new concrete slabs to cure for at least seven (7) days.

- A treated 2 x 4" (5,1 x 10,2 cm) sill plate is required when installing your shed on concrete. **Hint: Use treated lumber in your kit or purchase full length treated lumber.**
- Use a high quality exterior grade caulk beneath all sill plates.
- Fasten 2 x 4" (5,1 x 10,2 cm) sill plates to slab using approved concrete anchors (**fasteners not included**).
- Check local code for concrete foundation requirements.

NOTES

ADDITIONAL MATERIALS

FOUNDATION OR FLOOR MATERIALS

- This shed kit includes a wood floor system.
- This shed does not include any leveling materials.
- See the **FLOOR LEVELING** section on page 7 for recommended methods and suggested materials to properly level your floor, as this will vary depending on your specific site.

REINFORCED WOOD FLOOR FRAME (OPTIONAL)

IMPORTANT! The included floor has been designed for general use. Depending on your specific use you may want to construct a heavy duty floor frame by adding additional floor joists (shown below as shaded). Below is a list of additional materials (not included):

- x4** 2 x 4 x 8' (5,1 x 10,2 x 243,8 cm) Treated Lumber
Cut to 2 x 4 x 93" (5,1 x 10,2 x 236,2 cm)
- x16** ea. 3" (7,6 cm) Hot Dipped Galvanized Nails

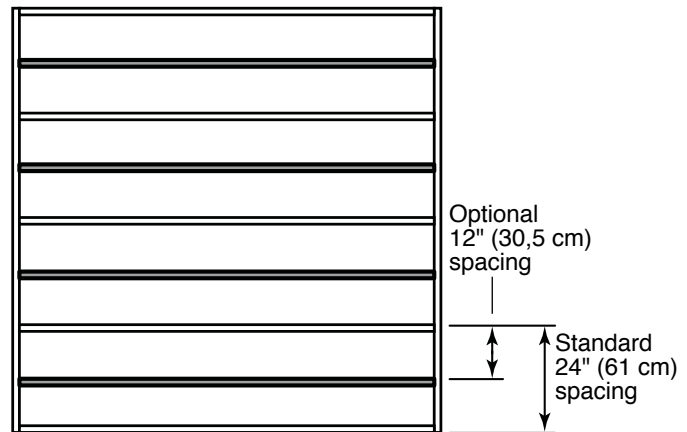

COMPLETING YOUR SHED

You will need these additional materials:

- | | |
|--|---|
| <input type="checkbox"/> 3-TAB SHINGLES 4 Bundles | <input type="checkbox"/> 1" GALVANIZED ROOFING NAILS.... 2 Lbs
For shingles. |
| <input type="checkbox"/> PAINT FOR SIDING 2 Gallons
Use 100% acrylic latex exterior paint. (2) coats recommended. | <input type="checkbox"/> PAINT FOR TRIM1 Quart
Use 100% acrylic latex exterior paint. |
| <input type="checkbox"/> CAULK 2 Tubes
Use acrylic latex exterior caulk that is paintable.  | <input type="checkbox"/> WOOD GLUE Exterior Rated |

OPTIONAL MATERIALS

- | | |
|---|--|
| <input type="checkbox"/> DRIP EDGE 40 Feet | <input type="checkbox"/> #15 ROOFING FELT
To cover 75 Sq. Ft. of roof area. |
| | <input type="checkbox"/> 1" GALVANIZED ROOFING NAILS..... 1/4 Lb
For roofing felt. |

REFER TO THE BACK OF THIS MANUAL AND THE MANUFACTURER'S INSTRUCTIONS FOR INSTALLATION OF SHINGLES, DRIP EDGE AND FELT.

PARTS IDENTIFICATION AND SIZES

Part identification is stamped on some parts.

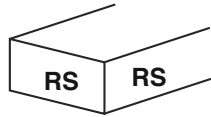

Treated lumber is stamped:



WOOD SIZE CONVERSION CHART

Nominal Board Size	Actual Size
2" x 4".....	1-1/2" x 3-1/2" (3,8 x 8,9 cm)
1" x 4".....	3/4" x 3-1/2" (1,9 x 8,9 cm)
2" x 3".....	1-1/2" x 2-1/2" (3,8 x 6,3 cm)
1" x 3".....	3/4" x 2-1/2" (3,8 x 6,3 cm)

• Check these locations for part stamp.

PARTS LIST



INVENTORY YOUR PARTS before you begin.

We suggest sorting parts by the category they are listed in.

Treated lumber is stamped:

FLOOR

- x2 TREATED 2 x 4 x 92-1/2" (5,1 x 10,2 x 235 cm) TREATED
- x5 TREATED 2 x 4 x 93" (5,1 x 10,2 x 236,2 cm)

WALL

- x1 GAA 1 x 3 x 5" (2,5 x 7,6 x 12,7 cm) **GAUGE BLOCK FOR 3/4" (1,9 cm) MEASUREMENT**
- x2 DQ 2 x 3 x 11-7/8" (2,5 x 7,6 x 30,2 cm)
- x2 BV 2 x 3 x 17-1/2" (2,5 x 7,6 x 44,5 cm)
- x1 LW 2 x 3 x 23-7/8" (2,5 x 7,6 x 60,6 cm)
- x2 CI 2 x 3 x 34" (5,1 x 7,6 x 86,4 cm)
- x11 FZ 2 x 3 x 66-1/2" (5,1 x 7,6 x 168,9 cm)
- x1 PS 2 x 3 x 91" (5,1 x 7,6 x 231,1 cm)
- x4 PNA 2 x 3 x 92-1/2" (5,1 x 7,6 x 235 cm)
- x2 PT 2 x 3 x 96" (5,1 x 7,6 x 243,8 cm)

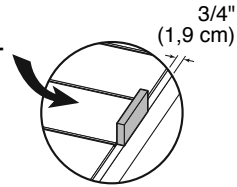

TRUSS

- x6 6 x 24" (15,2 x 61 cm)
- x6 WI 2 x 4 x 54-1/16" (5,1 x 10,2 x 129,8 cm)

TRIM

- x2 WQ 1 x 2 x 11" (2,5 x 5,1 x 27,9 cm)
- x2 WO 1 x 2 x 14" (2,5 x 5,1 x 35,6 cm)
- x4 WX 2 x 3 x 55-3/4" (5,1 x 7,6 x 141,6 cm)
- x1 WR 19/32 x 3 x 63" (1,5 x 7,6 x 160 cm)
- x4 3/8 x 1-3/4 x 71-1/4" (1 x 4,4 x 181 cm)
- x4 3/8 x 1-3/4 x 71-3/4" (1 x 4,4 x 182,2 cm)

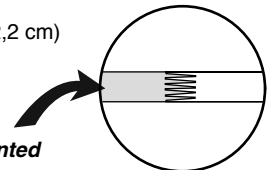

DOOR

- x2 OO 2 x 3 x 69" (5,1 x 7,6 x 175,3 cm) *Finger Jointed*

WALL PANELS, AND DOORS

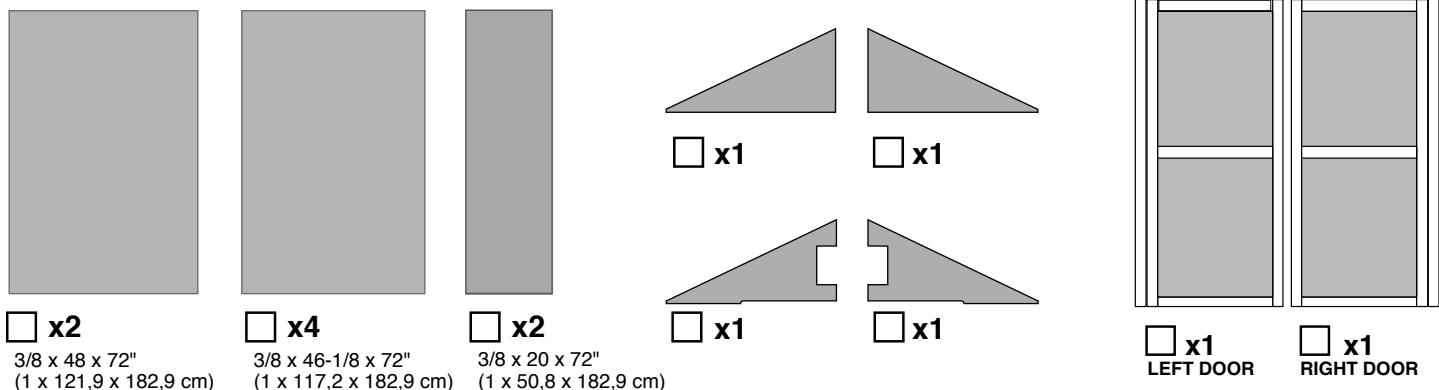

ROOF PANELS

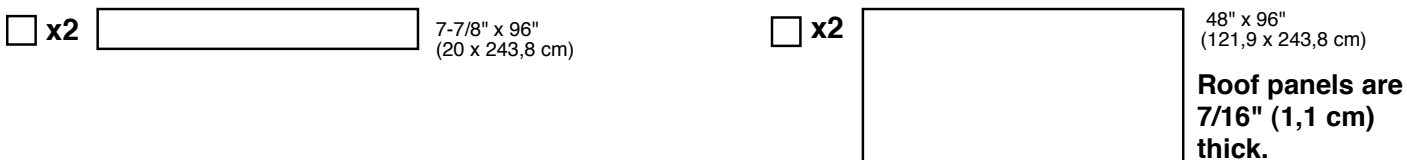

FLOOR PANELS

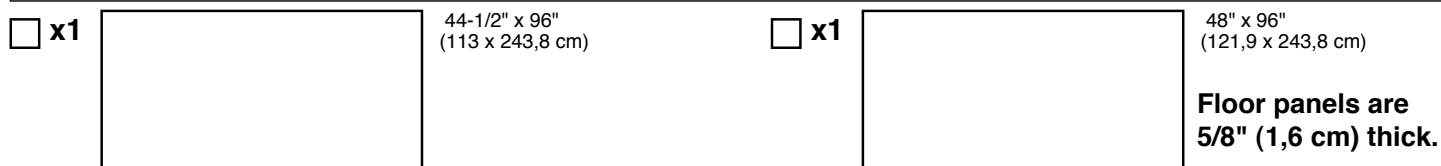

NAIL BOXES

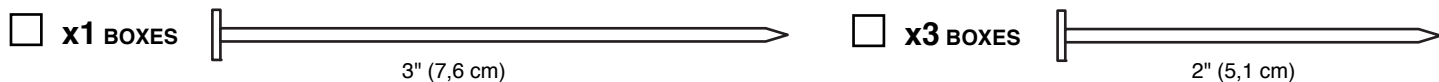

FASTENER/HARDWARE BAG

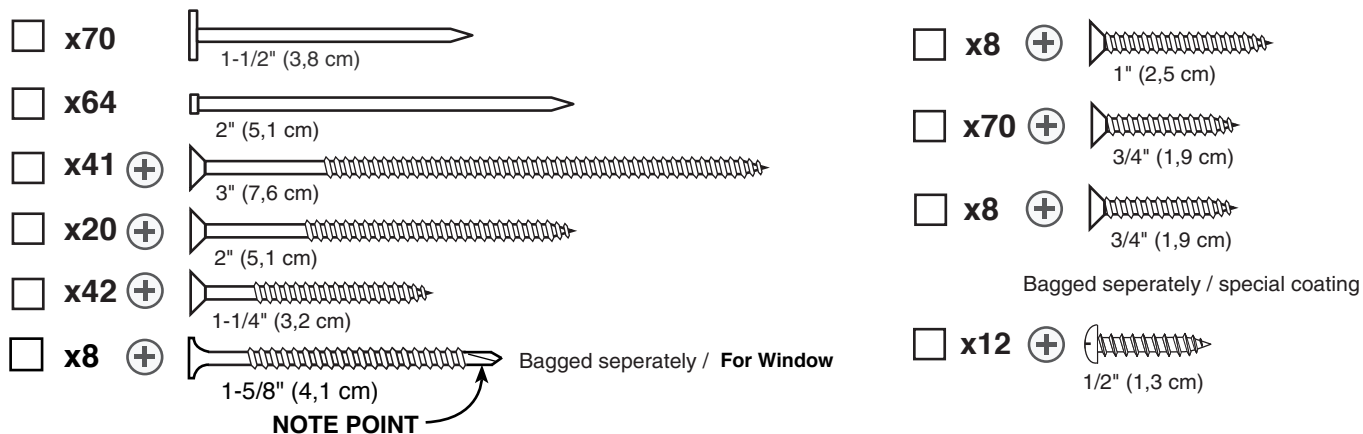

VENT, DOOR HARDWARE, AND WINDOW

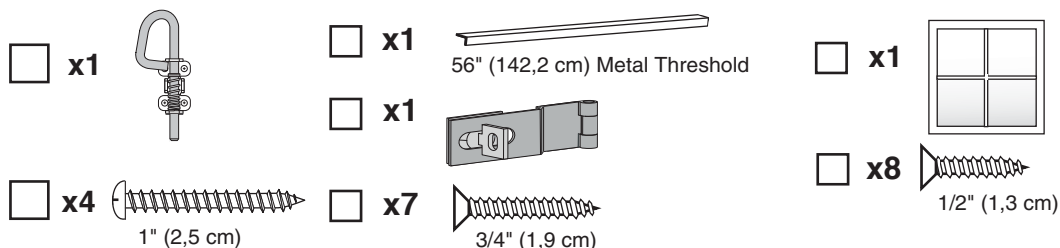

FLOOR LEVELING OPTIONS

There are multiple ways to level your floor frame. Our recommended leveling method is shown below.
Leveling materials are not included in this kit.

PREFERRED METHOD - 4x4 TREATED RUNNERS

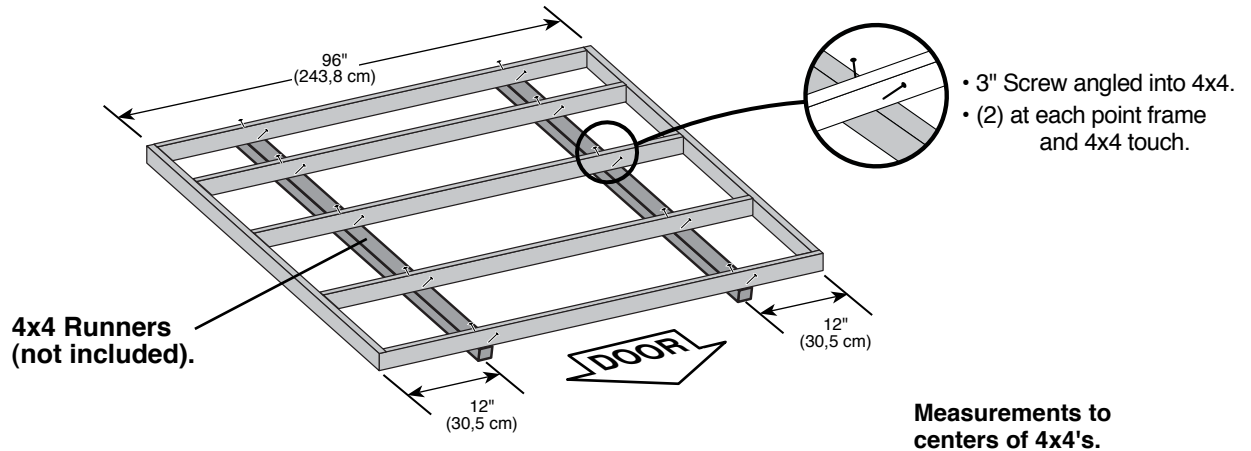

MATERIAL REQUIRED

x2 4" x 4" x 8' (10,2 x 10,2 x 243,8 cm) Treated Lumber

Fasteners for Frame to 4"x 4".
 (3" Screws shown as one option.) Minimum (20) 3" screws / exterior grade.

Use only wood treated for ground contact and fasteners approved for use with treated wood.

Always support frame seams.

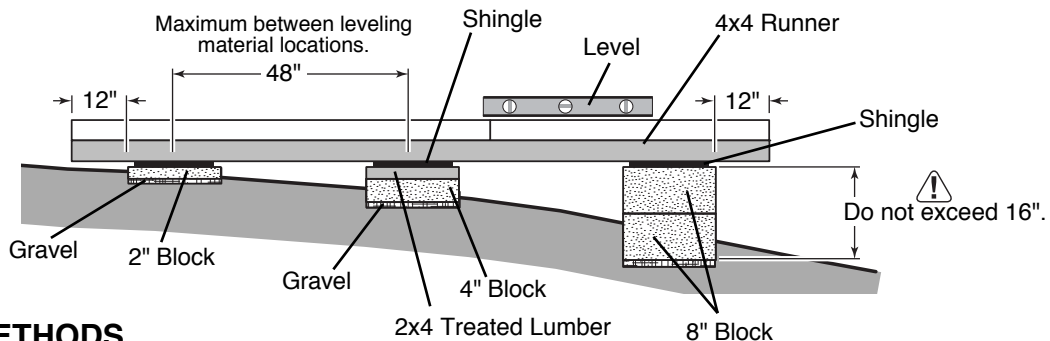

LEVELING METHODS

- Level under 4x4 runners only.
- Locate leveling material 12" from ends of runners and no more than 48" apart.
- Asphalt shingles should be used between 4x4 runners and blocks or treated lumber. Never use shingles in direct contact with ground.
- For best results and aiding in water drainage use gravel under each concrete block.

LEVELING MATERIALS

- Gravel
- Solid Masonry Blocks in 1", 2", 4" or 8" thickness
- 2x4 Treated Lumber
- Asphalt Shingles

Leveling higher than 16" not recommended.

CONCRETE

- If you are building your shed on a concrete foundation see the following page.

STANDARD FLOOR FRAME

PARTS REQUIRED: NOTE: Look for **TREATED** Stamp. x20  3" (7,6 cm)

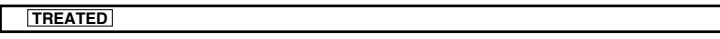
x5  2 x 4 x 93" (5,1 x 10,2 x 236,2 cm)

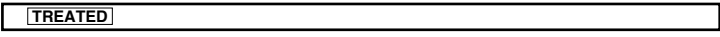
x2  2 x 4 x 92-1/2" (5,1 x 10,2 x 235 cm)

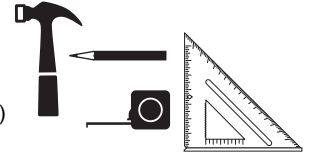

BEGIN

1 Orient parts as shown on flat surface. Measure and mark each dimension from end of boards

2 Use two 3" nails at each mark

FINISH

3 You have finished your floor frame. Proceed to level and square frame.



HINT: For easier nailing stand on frame.

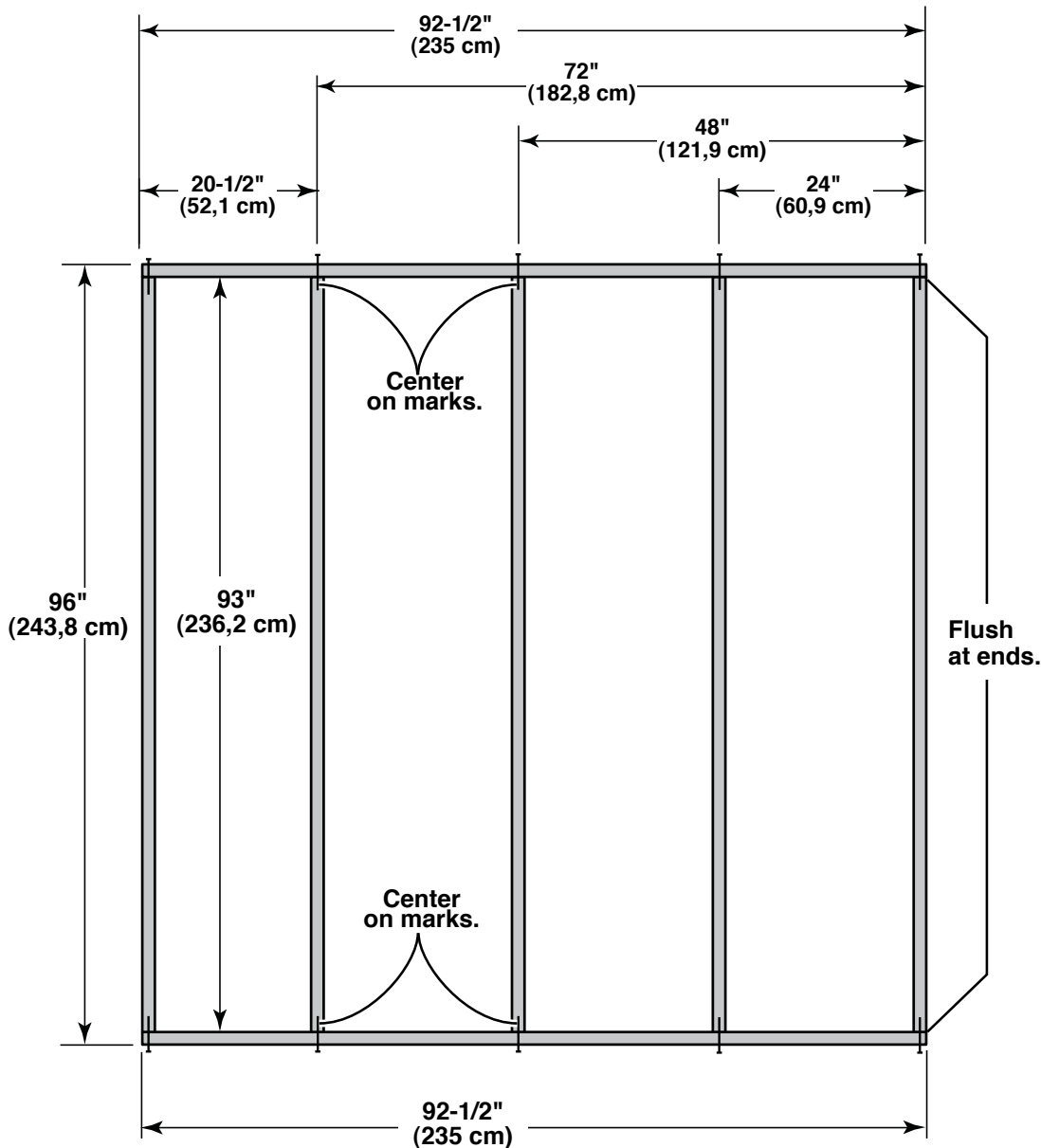
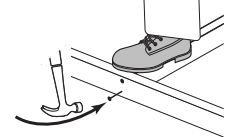

STOP!



LEVEL AND SQUARE FLOOR FRAME



STOP!

Before attaching floor decking, it is important to level and square the floor frame. A level and square floor frame is required to correctly construct your shed.

✓ **BEGIN**

- 1** ⚠ See page 7 for the preferred floor leveling method.
- 2** Use level and check the frame is level before applying floor panels.
- 3** Check for frame squareness by measuring diagonally across corners. If the measurements are the same, the frame is square. The diagonal measurement will be approximately 133-5/16" (338,6 cm).
- 4** When the frame is level and square secure one side of frame to the 4x4 runners using one fastener at ends of each runner. At the opposite end of the frame, secure the frame to 4x4 runners with one fastener at ends of each runner making sure the frame remains square (**Fig. A**).



FINISH

- 5** Once the floor frame is level and square fasten the frame at each point the frame contacts the 4x4 runners.

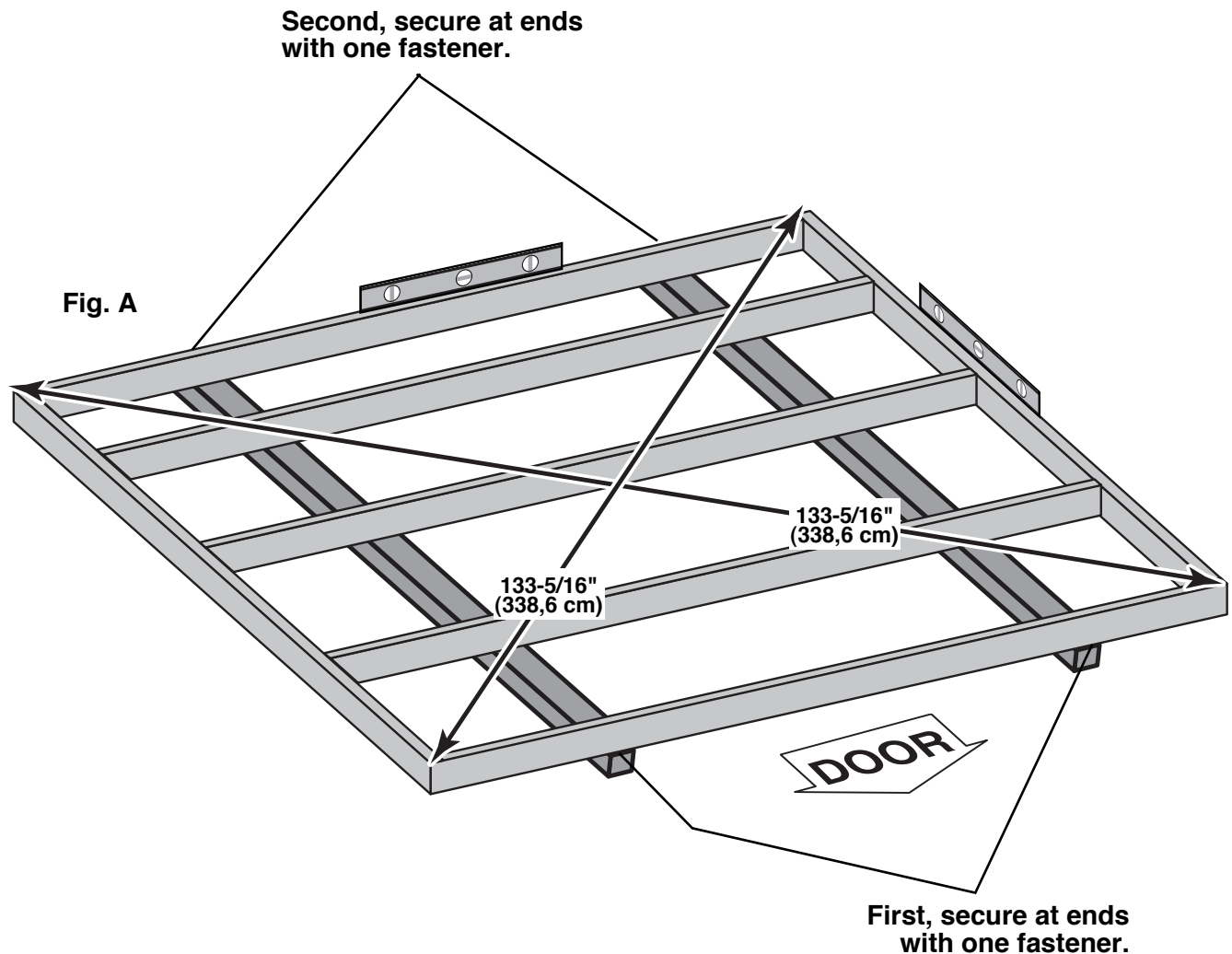

FLOOR PANELS

PARTS REQUIRED:

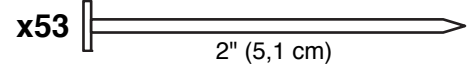
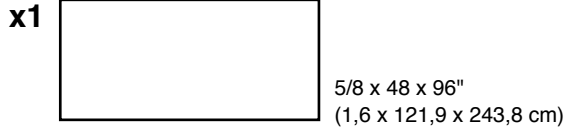

! Ensure your floor frame is square by installing one panel and squaring frame.

✓ **BEGIN**



- 1** Attach the **48 x 96"** panel with the rough side up (painted-grid lines side) with the 48" edge and corner flush to the floor frame (**Fig A**). Secure panel with two 2" nails in the corners.
- 2** Move to the opposite end. Using the long edge of the panel as a lever move the panel side-to-side until the top corner is flush to the floor frame (**Fig. B**). Secure panel with two 2" nails in the corners.
- 3** Check the floor frame is square by measuring diagonally across the frame corners. If the measurements are the same, your floor frame is square. The measurement will be approximately 133-5/16" (**Fig. C**).
- 4** Continue attaching the panel using 2" nails 6" apart on edges and 12" apart inside panel. Use a chalk line or use pre-painted grid lines to nail into joists under panel.

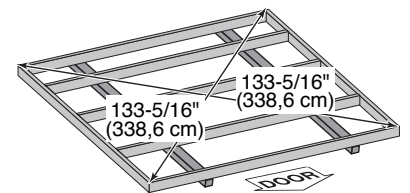
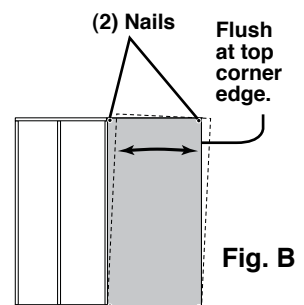
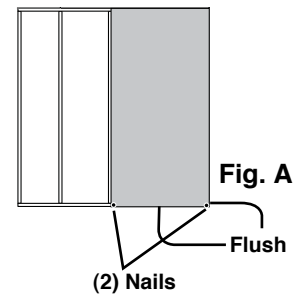
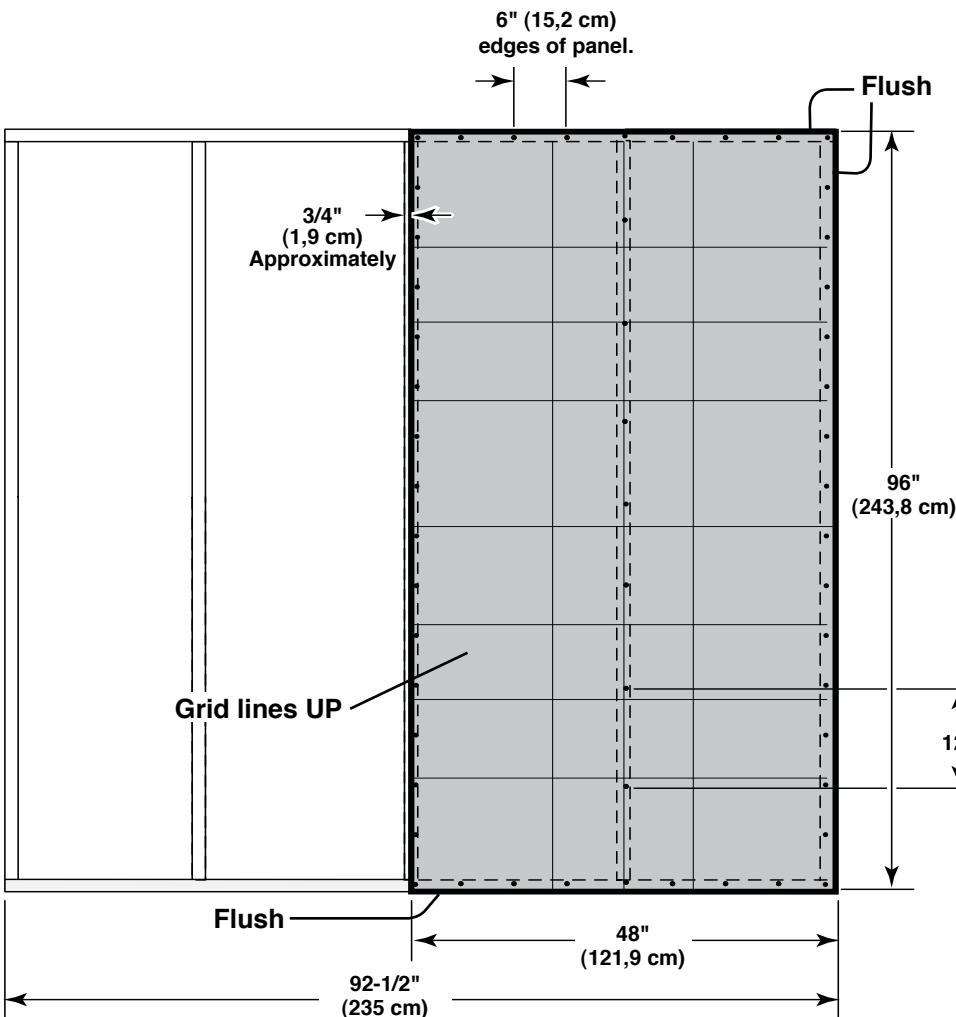

FLOOR PANELS

PARTS REQUIRED:

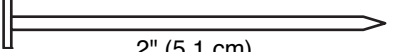
x53  2" (5,1 cm)



5/8 x 44-1/2 x 96"
(1,6 x 113 x 243,8 cm)

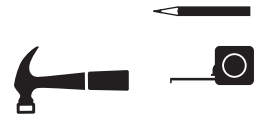

5 Continue by installing 44-1/2 x 96" panel with rough side up (painted grid lines).

6 Use a chalk line or grid lines on panels for 2" nails 6" apart on edges and 12" apart inside panel.



7 You have finished Installing your floor panels.

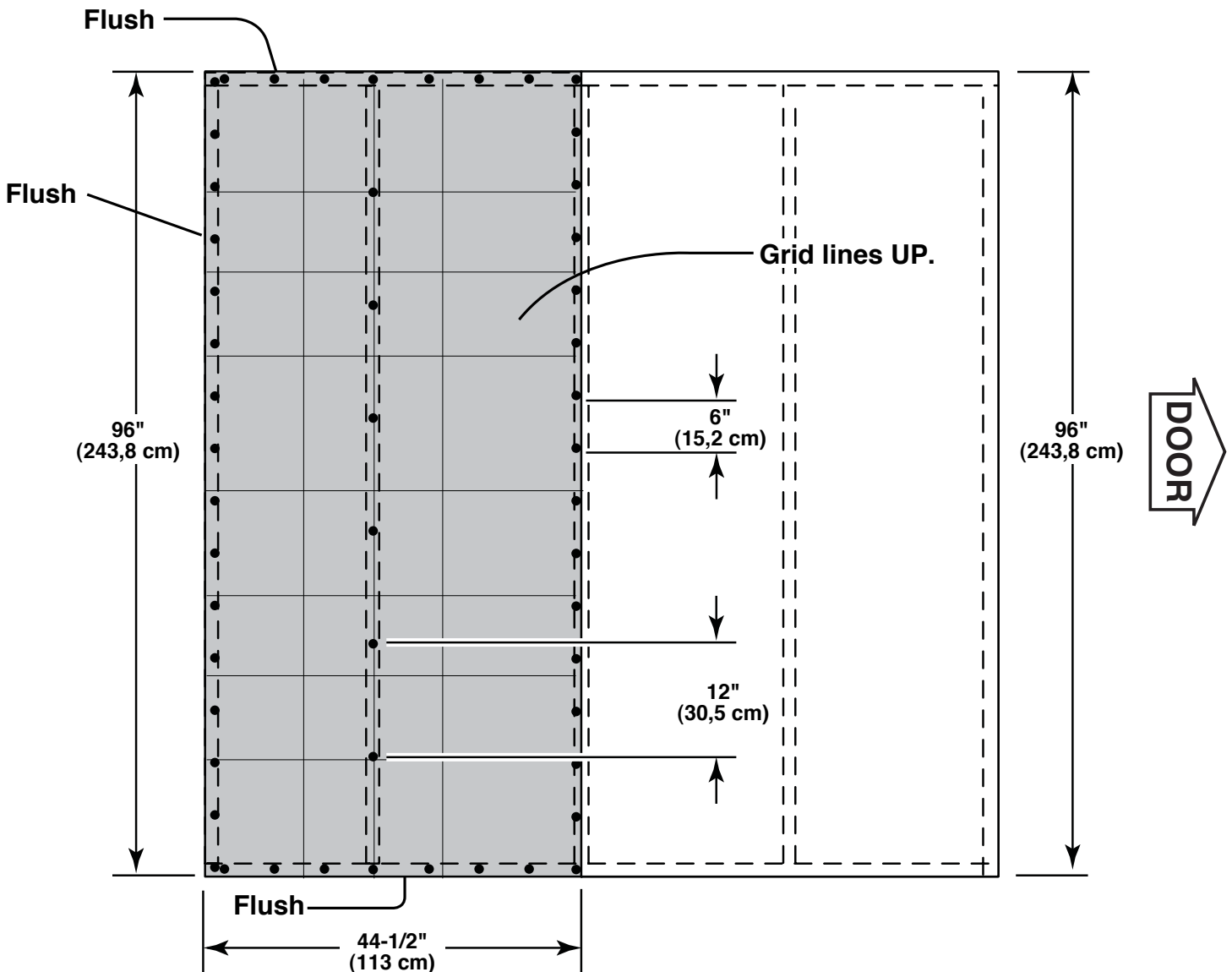

! IMPORTANT!



STOP! Check the floor frame is level after installing floor panels. Re-level if needed.

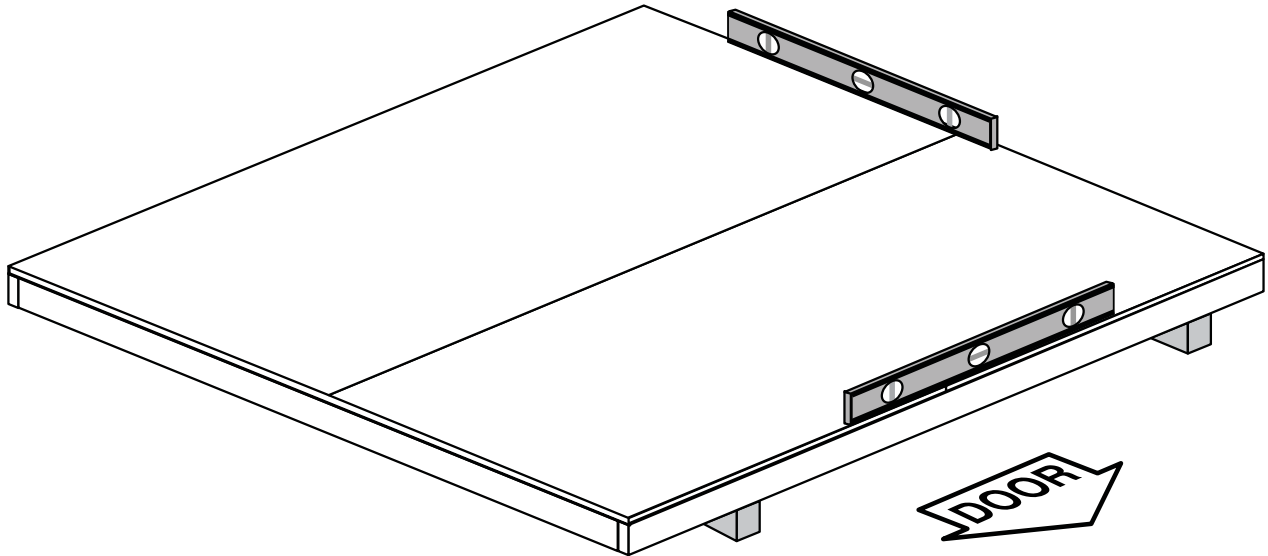

• The floor should be used as a stable work surface for wall construction.

HINT: • Organize your assembly procedure during the build process to avoid over-handling of the walls.

BACKWALL

SIDEWALL

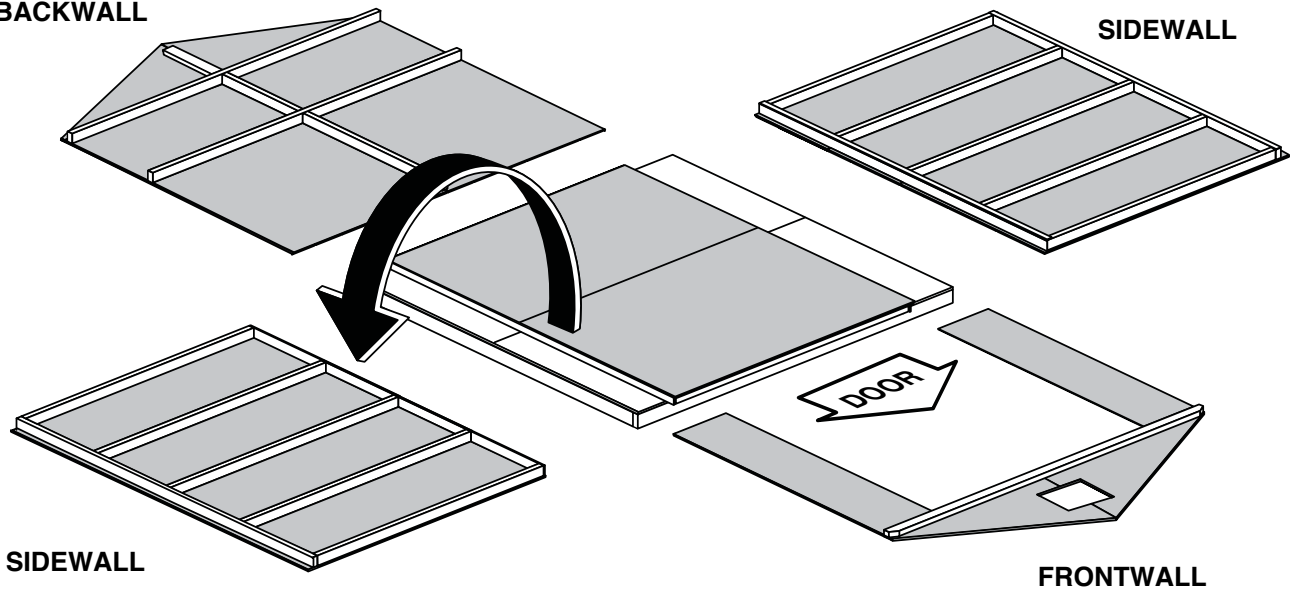

SIDE WALL FRAMES

PARTS REQUIRED:

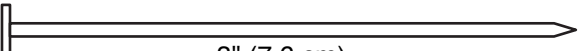
x40  3" (7,6 cm)

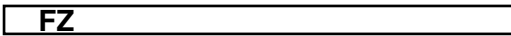
x10 **FZ** 
2 x 3 x 66-1/2" (5,1 x 7,6 x 168,9 cm)

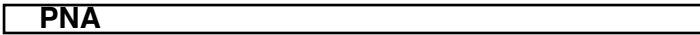
x4 **PNA** 
2 x 3 x 92-1/2" (5,1 x 7,6 x 235 cm)

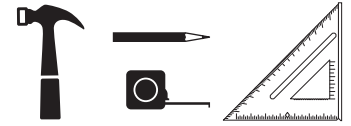

✓ **BEGIN**

1 Orient parts on edge on floor. Measure and mark from end of boards.

IMPORTANT! You will build two walls the same.

2 Use two 3" nails at each mark.

FINISH

3 You have finished building one side wall frame. Proceed to attach wall panels.

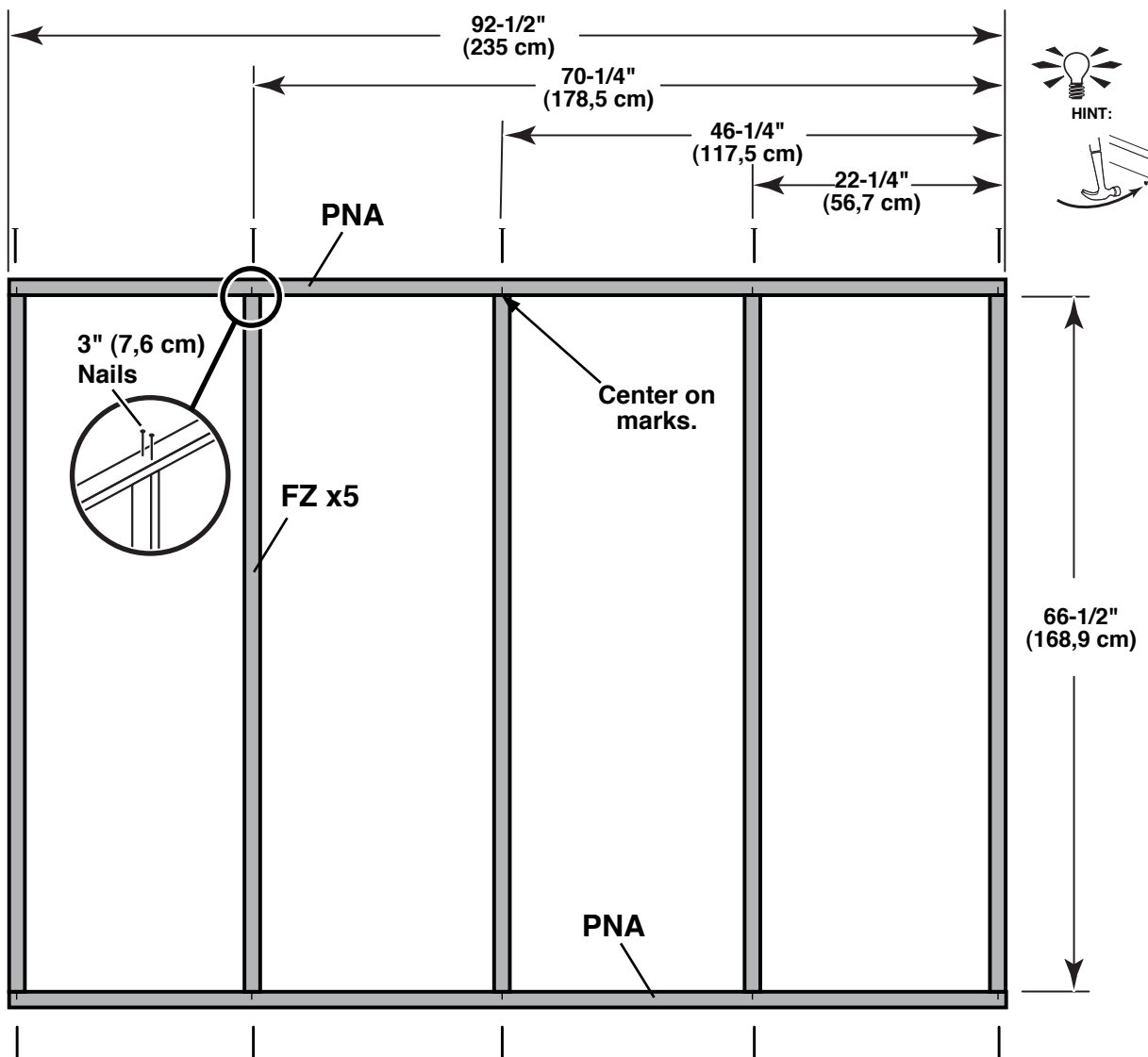

SIDE WALL PANELS

PARTS REQUIRED:



3/8 x 46-1/8 x 72" (1 x 117,2 x 182,8 cm)



3/4"

GAUGE BLOCK



2x3"

GAUGE BLOCK

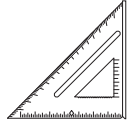
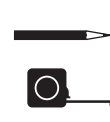
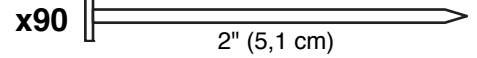

Ensure your wall frame is square by installing one panel and squaring frame.

✓ BEGIN

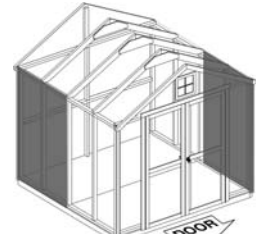

1 Place a 46-1/8 x 72" panel onto wall frame with primed side up as shown.

Locate the panel 1-1/2" above the top plate. Use a **DQ** as a gauge block for the 1-1/2" top overhang measurement. Use the **GAA** gauge block to mark the 3/4" side measurement on the wall stud. Secure panel with two 2" nails in the corners (**Fig. A**).

2 Move to the opposite end. Using the long edge of the panel as a lever, move the panel side-to-side until you have a 3/4" measurement on the wall stud. Secure corner with two 2" nails (**Fig. B**).

3 Nail the panel using 2" nails 6" apart on edges and 12" apart inside panel.



For squareness maintain 3/4" and 1-1/2" measurement along panel edge.

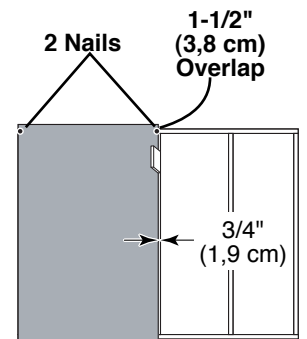
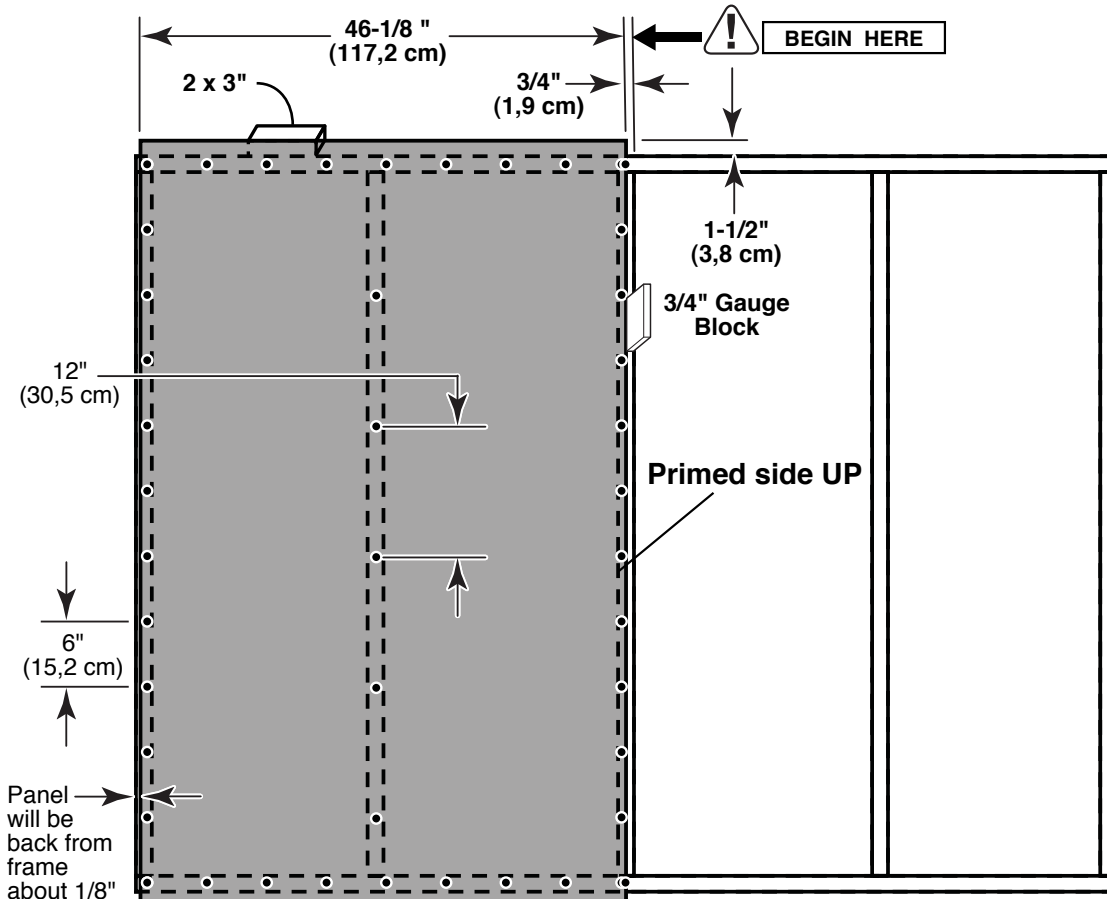
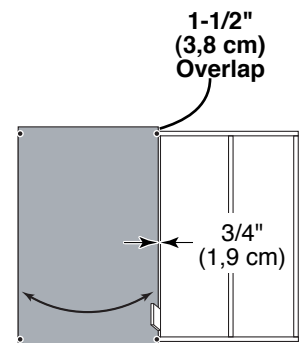

Fig. A



2 Nails

Fig. B

SIDE WALL PANELS

PARTS REQUIRED:

x2



3/8 x 46-1/8 x 72" (1 x 117,2 x 182,8 cm)



**2x3"
GAUGE BLOCK**

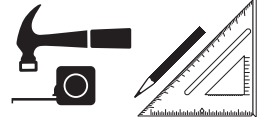
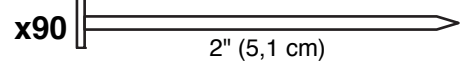

4 Place 46-1/8" panel on frame as shown with primed side facing up flush with first panel. Nail using 2" nails 6" apart on edges and 12" apart inside panel.

5 Carefully flip your sidewall over. Repeat **STEPS 1-4** to assemble your second side wall.



FINISH

6 You have finished building both of your side walls.

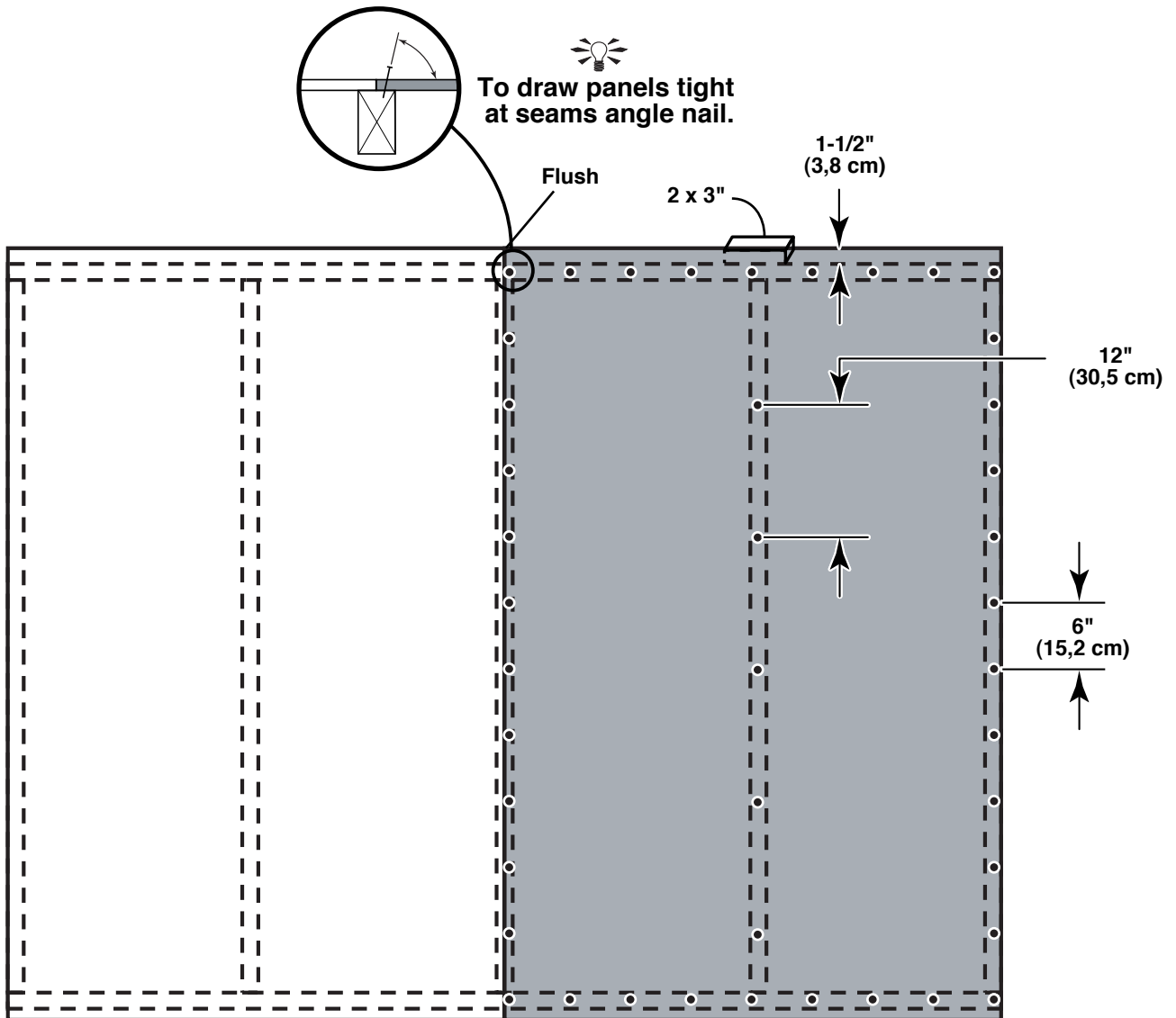
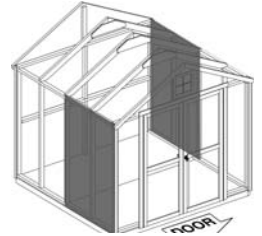

BACK WALL FRAME

PARTS REQUIRED:

x1 **CI**
2 x 3 x 34" (5,1 x 7,6 x 86,4 cm)

x1 **PS**
2 x 3 x 91" (5,1 x 7,6 x 231,1 cm)

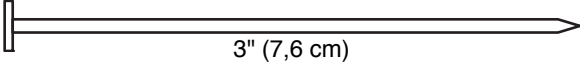
x2  3" (7,6 cm)

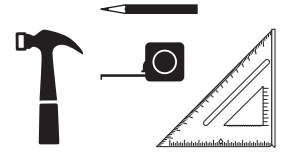

✓ **BEGIN**

- 1 Orient **CI** on flat using a gusset as a temporary spacer.
- 2 Center **PS** flush on **CI** on edge on floor as shown (**Fig. A**).
- 3 Nail using two 3" nails at each connection.

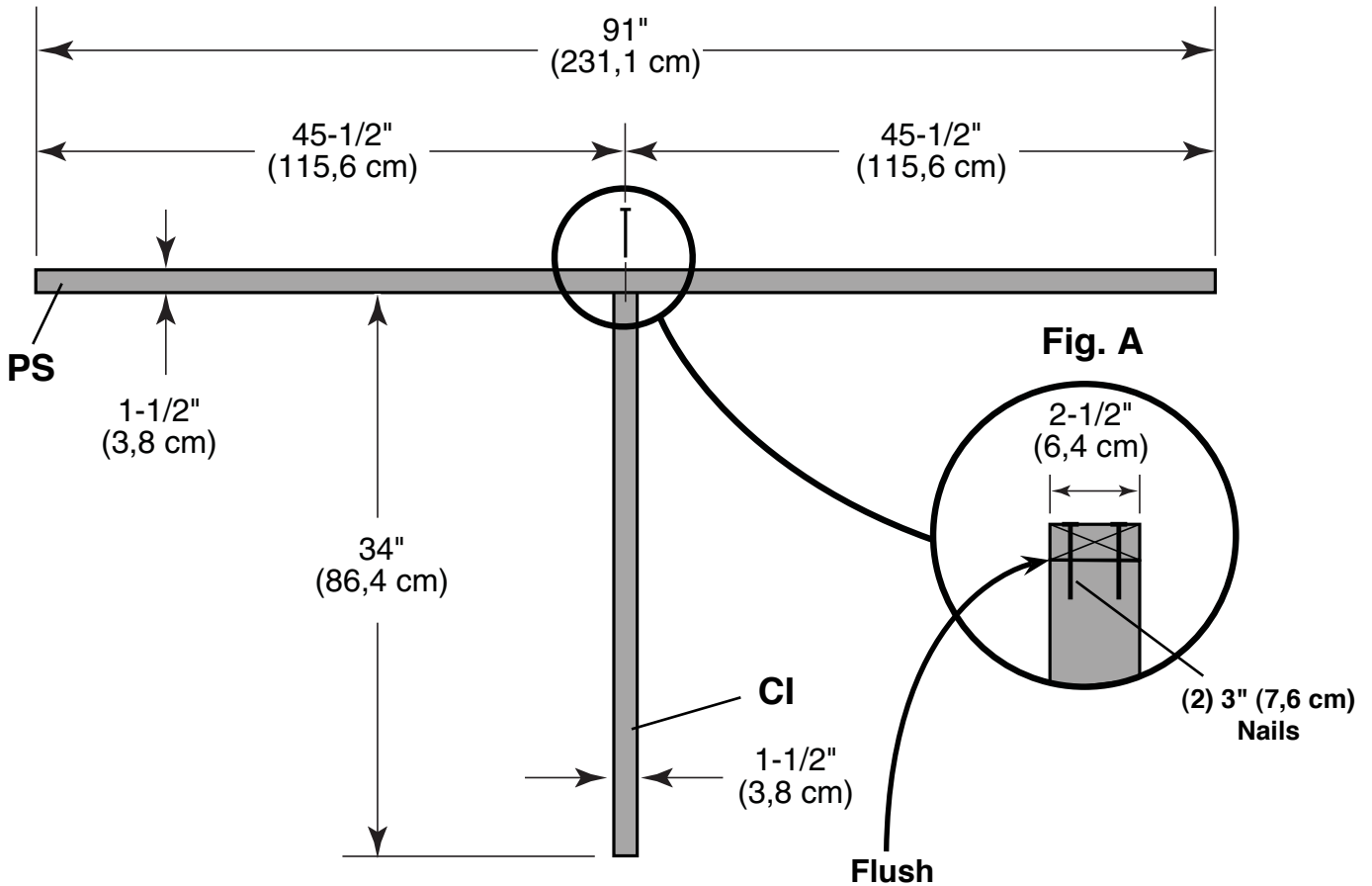

BACK WALL PANELS

PARTS REQUIRED:



3/8 x 48 x 72"
(1 x 121,9 x 182,9 cm)

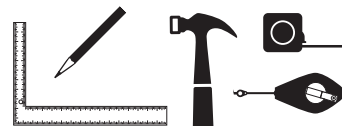
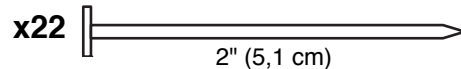

✓ BEGIN

- 1 Place **LEFT** panel on back frame as shown with primed side facing up.
- 2 Secure Using 2" nails 6" apart on edges and 12" apart inside panel.

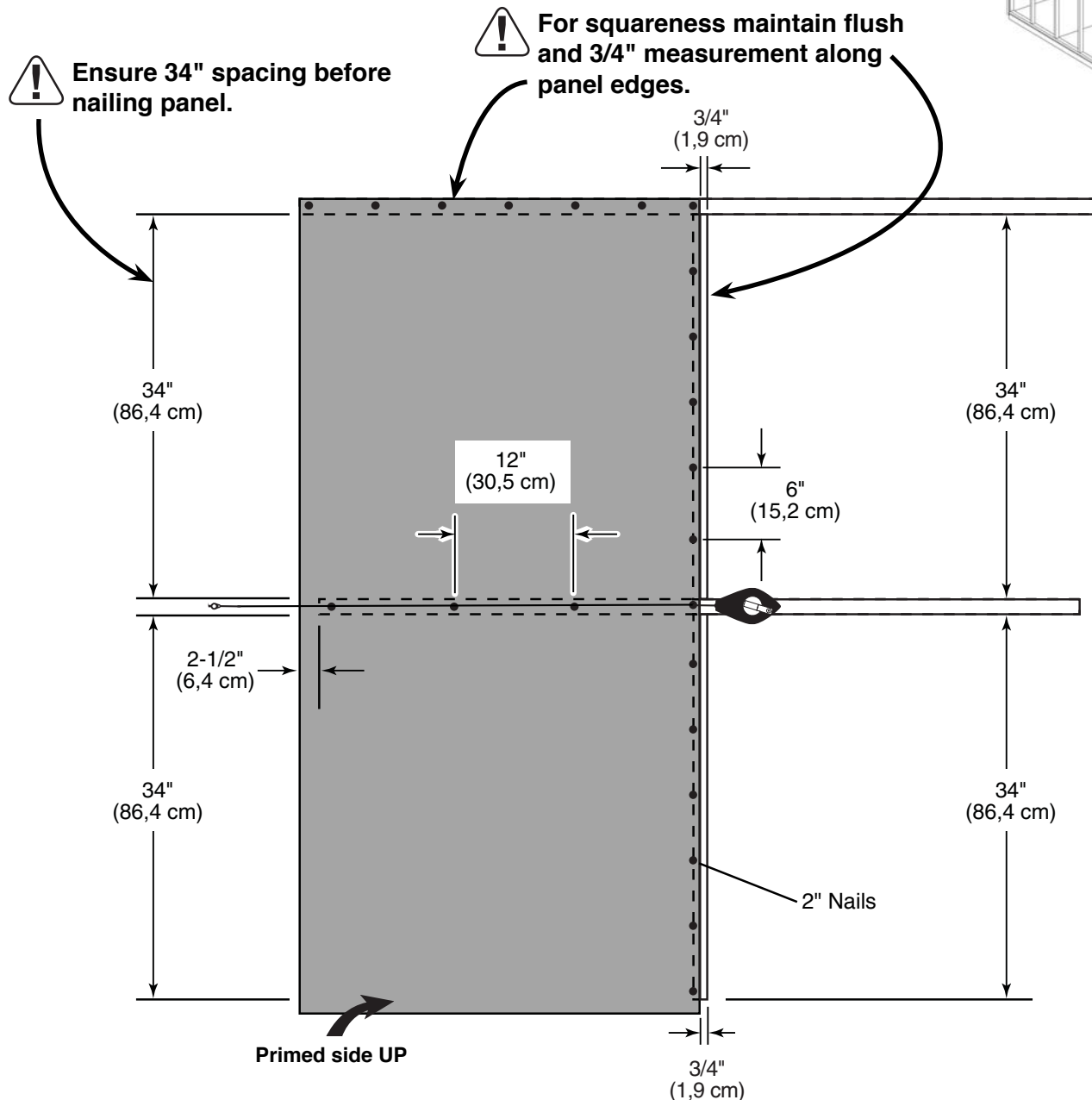

BACK WALL PANELS

PARTS REQUIRED:



x1
3/8 x 48 x 72"
(1 x 121,9 x 182,9 cm)

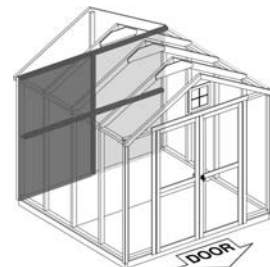
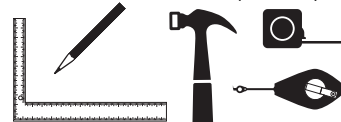
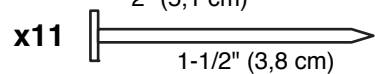
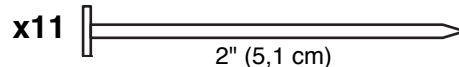

3 Place **RIGHT** panel on back frame as shown with primed side facing up and flush to panel.

Ensure 34" (86,4 cm) between **PT** and **PS**.

4 Secure Using 2" nails 6" apart on edges and 12" apart inside panel.



FINISH

5 You have finished installing your back wall panels.

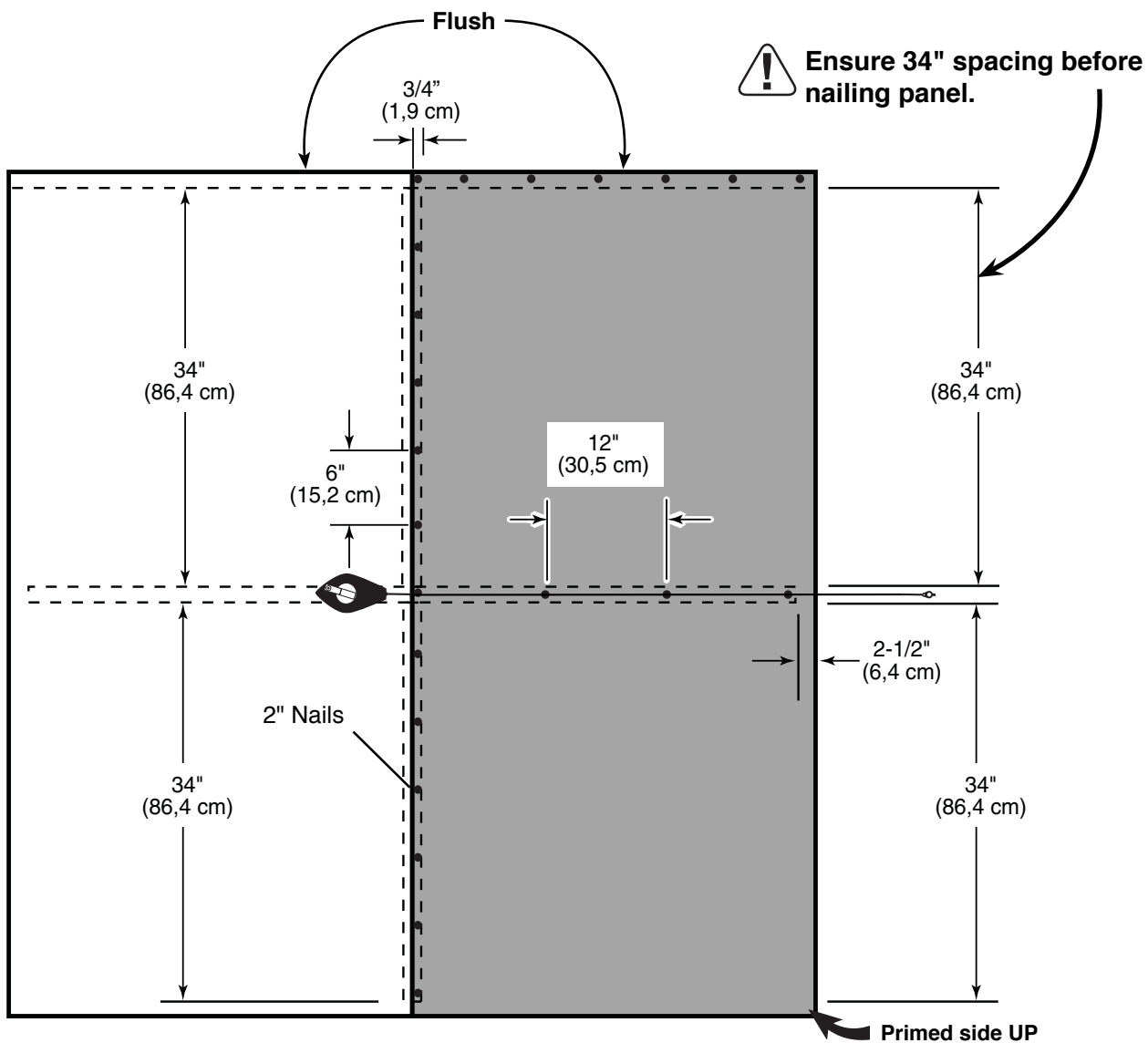

FRONT WALL FRAME

PARTS REQUIRED:

x2 
3/8 x 20 x 72" (1 x 50,8 x 182,9 cm)

x2 **BV** 
2 x 3 x 17-1/2" (5,1 x 7,6 x 44,5 cm)
TEMPORARY SUPPORT

x1 **PT** 
2 x 3 x 96" (5,1 x 7,6 x 243,8 cm)

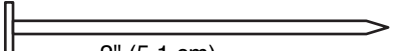
x8 
2" (5,1 cm)

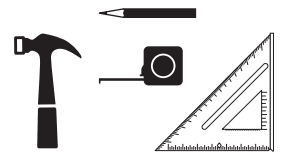

✓ BEGIN

- 1** Orient **PT** on edge and place **LEFT** panel on **PT** as shown with primed side facing up.
Use **BV** as a temporary support as shown.
- 2** Nail using 2" nails 4" apart.
- 3** Repeat steps 1-2 for **RIGHT** panel.

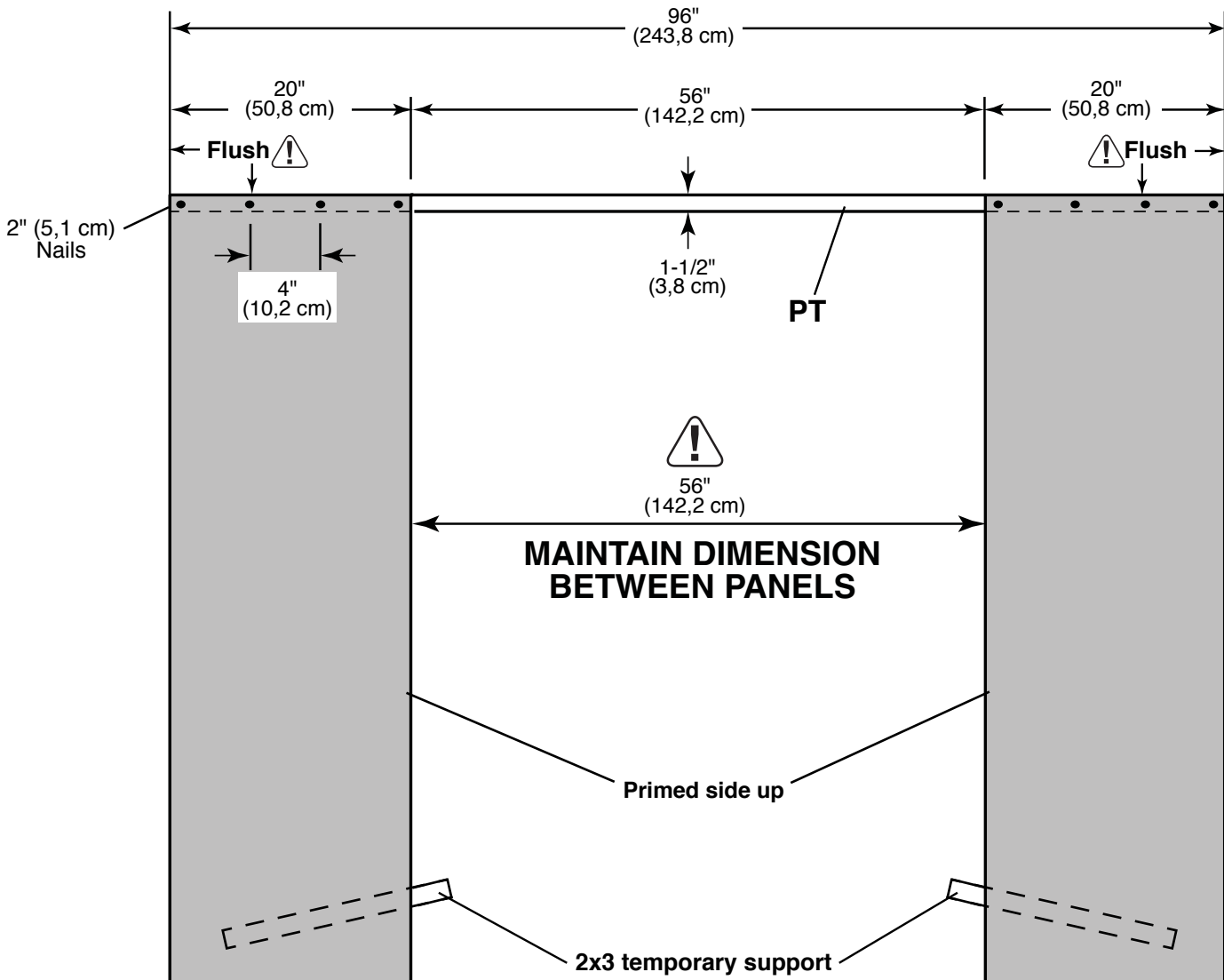
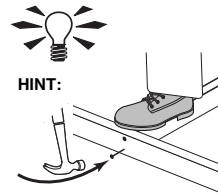

FRONT WALL PANELS

PARTS REQUIRED:

x2 **BV**
2 x 3 x 17-1/2" (5,1 x 7,6 x 44,5 cm)

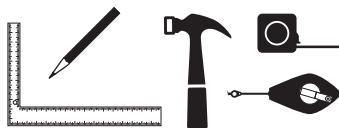

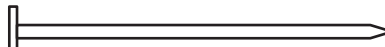
x6  2" (5,1 cm)

✓ BEGIN

- 1 Position **BV** on edge, 2-1/2" from outside edge and 1" from bottom edge of LEFT wall panel. (**Fig A.**)
- 2 Nail **BV** to wall panel using (3) 2" Nails.
- 3 Repeat step 1-2 for **RIGHT** wall panel. (**Fig B.**)



FINISH

- 4 You have finished building your front wall.

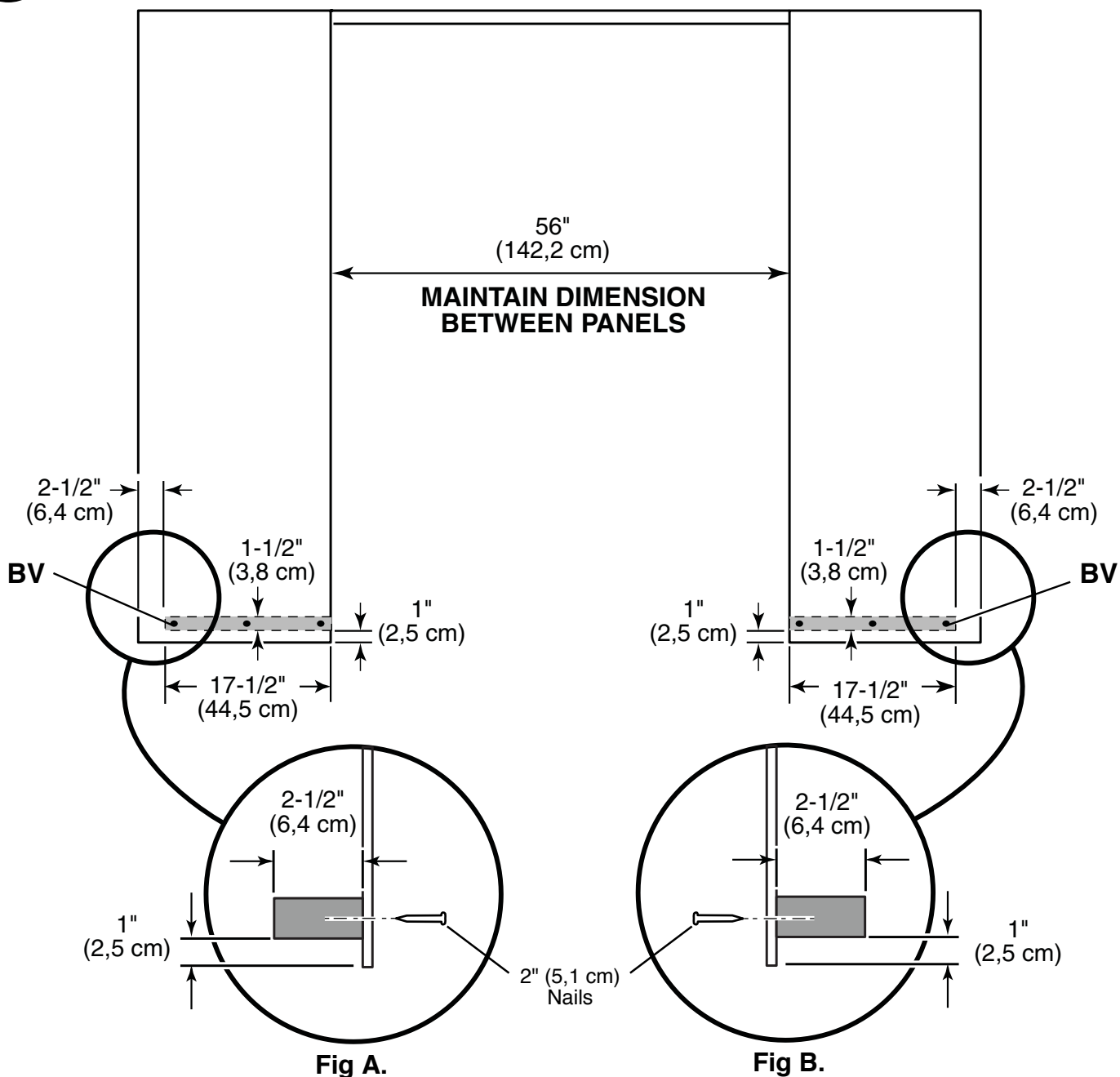

FRONT WALL TOP PLATE

PARTS REQUIRED:

x1 **FZ**
2 x 3 x 66-1/2" (5,1 x 7,6 x 168,9 cm)

x1 **GUSSET**
TEMPORARY SPACER

x5  3" (7,6 cm)



✓ **BEGIN**

- 1 Center **FZ** on **PT** on flat, flush to front wall panel (**Fig. A**).
- 2 Secure using five 3" screws on angle spaced evenly.
- 3  Mark center of door opening for later alignment.

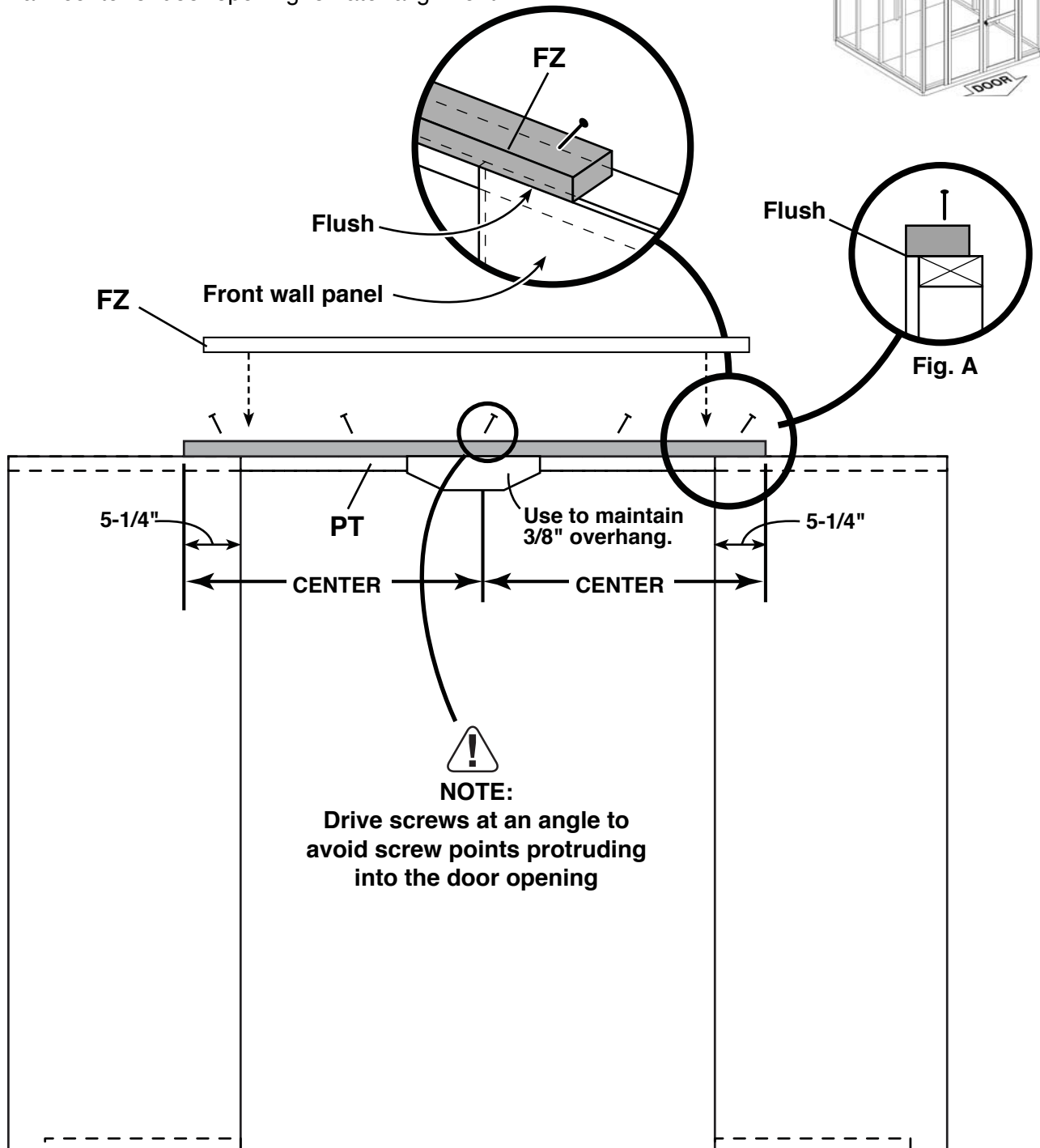

SIDE WALL INSTALLATION

PARTS REQUIRED (TEMPORARY):

x1 **OO**
 2 x 3 x 69" (5,1 x 7,6 x 175,3 cm)
 TEMPORARY SUPPORT



x2 3" (7,6 cm)
 x8 3" (7,6 cm)
 x17 2" (5,1 cm)

✓ BEGIN

1 Center side wall assembly on the 92-1/2" (235 cm) floor dimension.

Ensure 1-1/2" measurement is on top

2 Use **OO** as a temporary brace. Secure with two 3" screws.

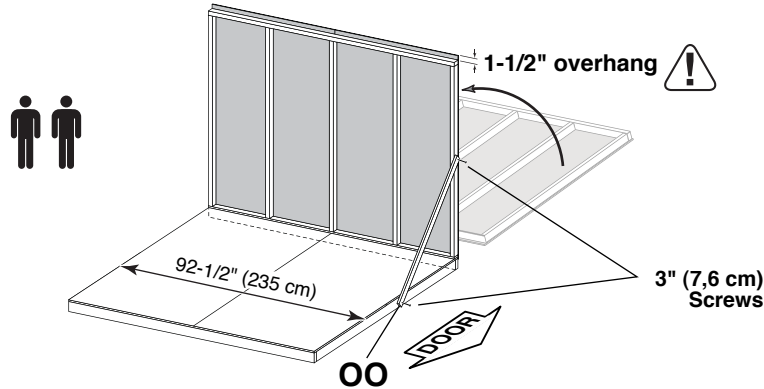

3 First, nail lower edge of panel to floor frame using 2" nails 6" apart. Angle nail to hit floor frame (**Fig. A**).

4 Nail side wall bottom plate to floor using eight 3" nails.
 (Nail two 3" nails between each stud through bottom plate)

FINISH

5 You have finished standing your side wall.
 Repeat **steps 1-4** to stand second wall.

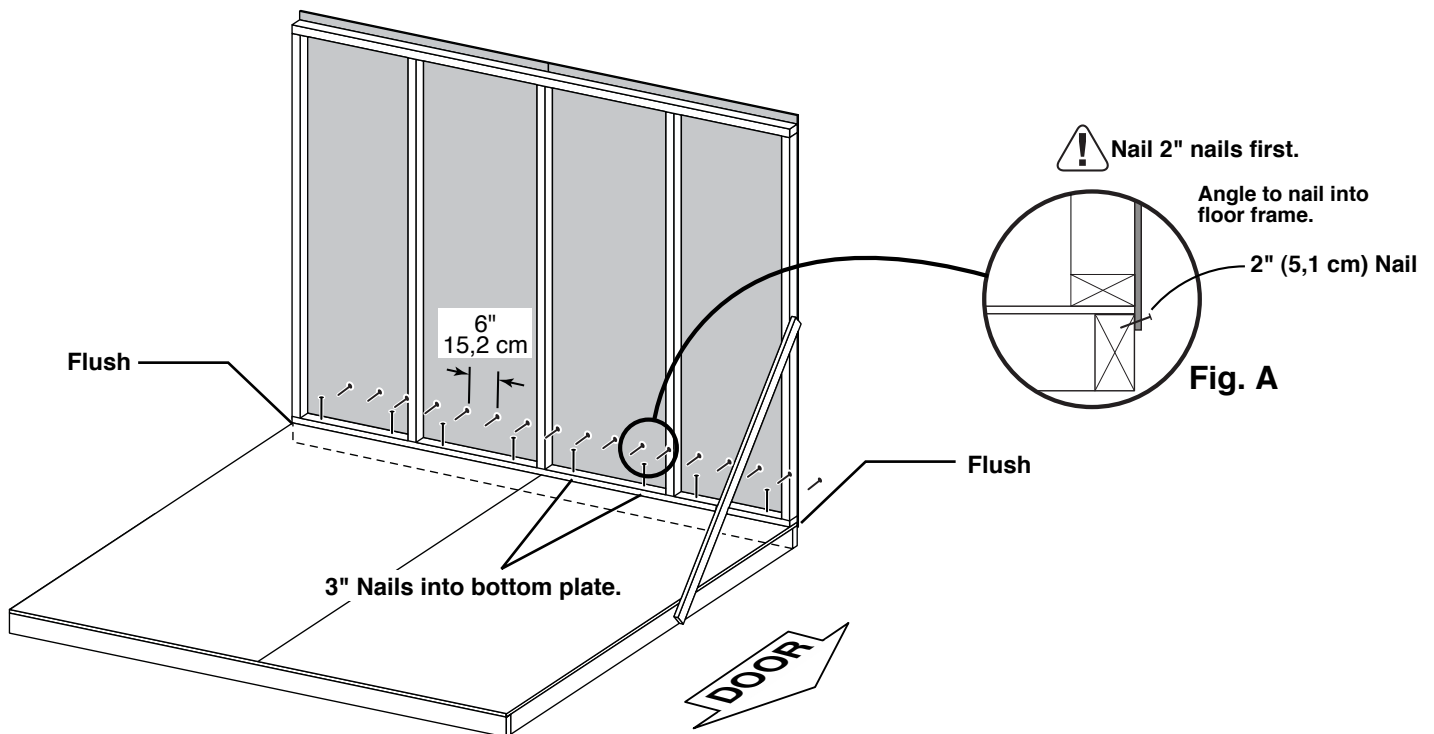

SIDE WALL INSTALLATION

PARTS REQUIRED:

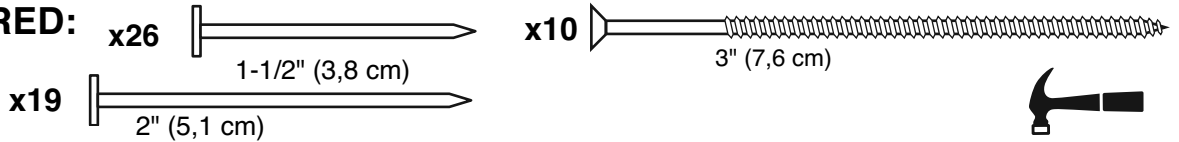

✓ **BEGIN**



It is important to secure the side wall in the following order:



- 1 Set back wall on side wall top plates and secure using two 3" screws on each side (**Fig. A**).
- 2 Nail lower edge of panel to floor frame using 2" nails 6" apart. Angle nail to hit floor frame (**Fig. B**).
- 3 Secure back wall upright to floor using two 3" screws (**Fig. C**).
- 4 Nail back wall panel to side wall stud using thirteen 1-1/2" nails at 6" apart.
- 5 Secure back wall center horizontal 2 x 3" using two 3" screws into back wall frame at an angle as shown (**Fig. D**).



FINISH

- 6 You have finished standing your back wall.

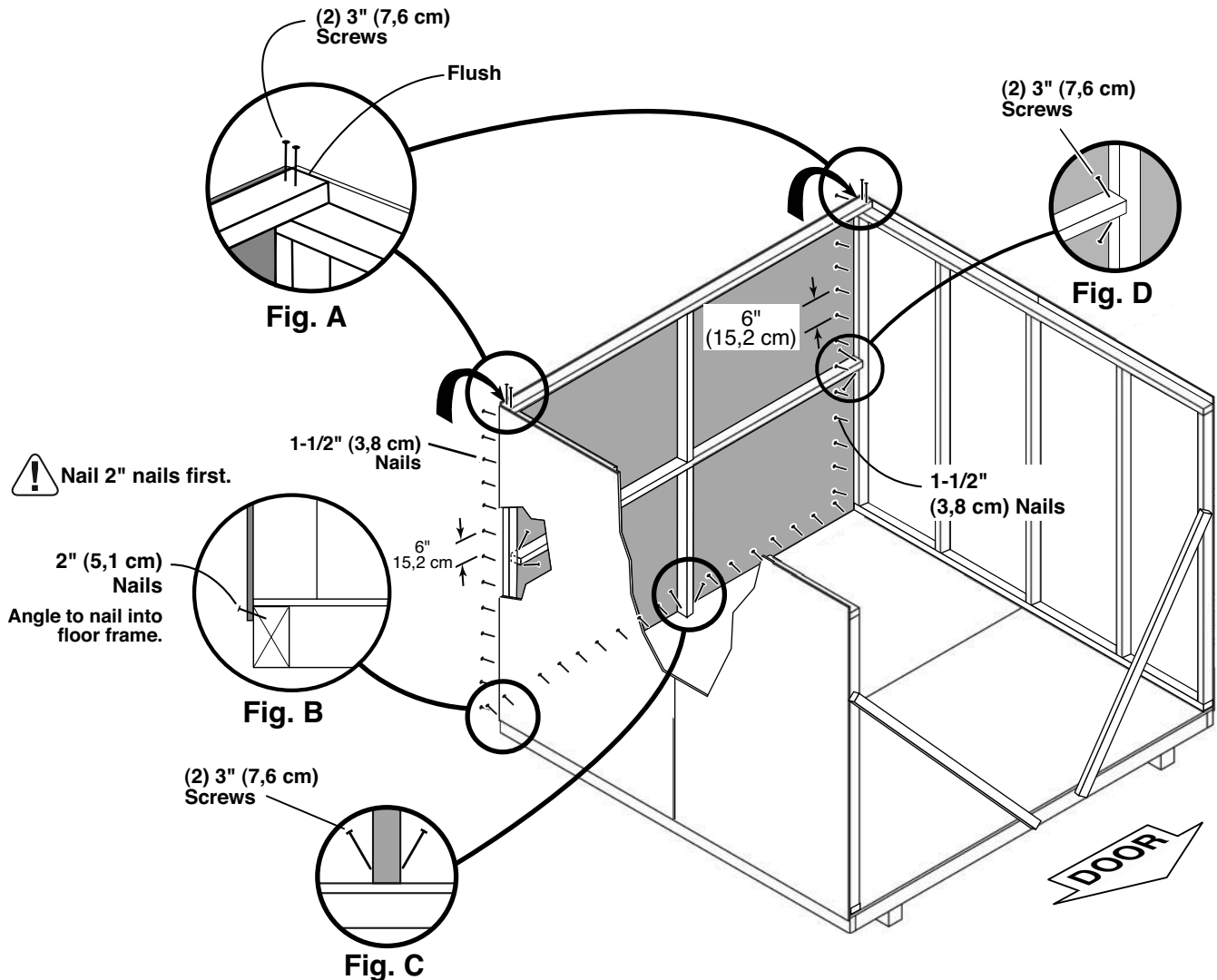

FRONT WALL INSTALLATION

PARTS REQUIRED:

x8 2" (5,1 cm)
 x26 1-1/2" (3,8 cm)

x4 3" (7,6 cm)
 x6 3" (7,6 cm)



✓ BEGIN



It is important to secure the front wall in the following order:



- 1 Center front wall assembly on floor, resting top plate on side walls.
- 2 Secure front wall top plate to side walls using two 3" screws (Fig. A, B).
- 3 Secure lower edge of panel to floor frame using eight 2" nails 6" apart. Angle nail to hit floor frame (Fig. C).
- 4 Secure bottom plates with three 3" nails on each side (Fig. C).
- 5 Nail front wall to side walls using 1-1/2" nails 6" apart (Fig. D).

FINISH

- 6 You have finished standing your walls.

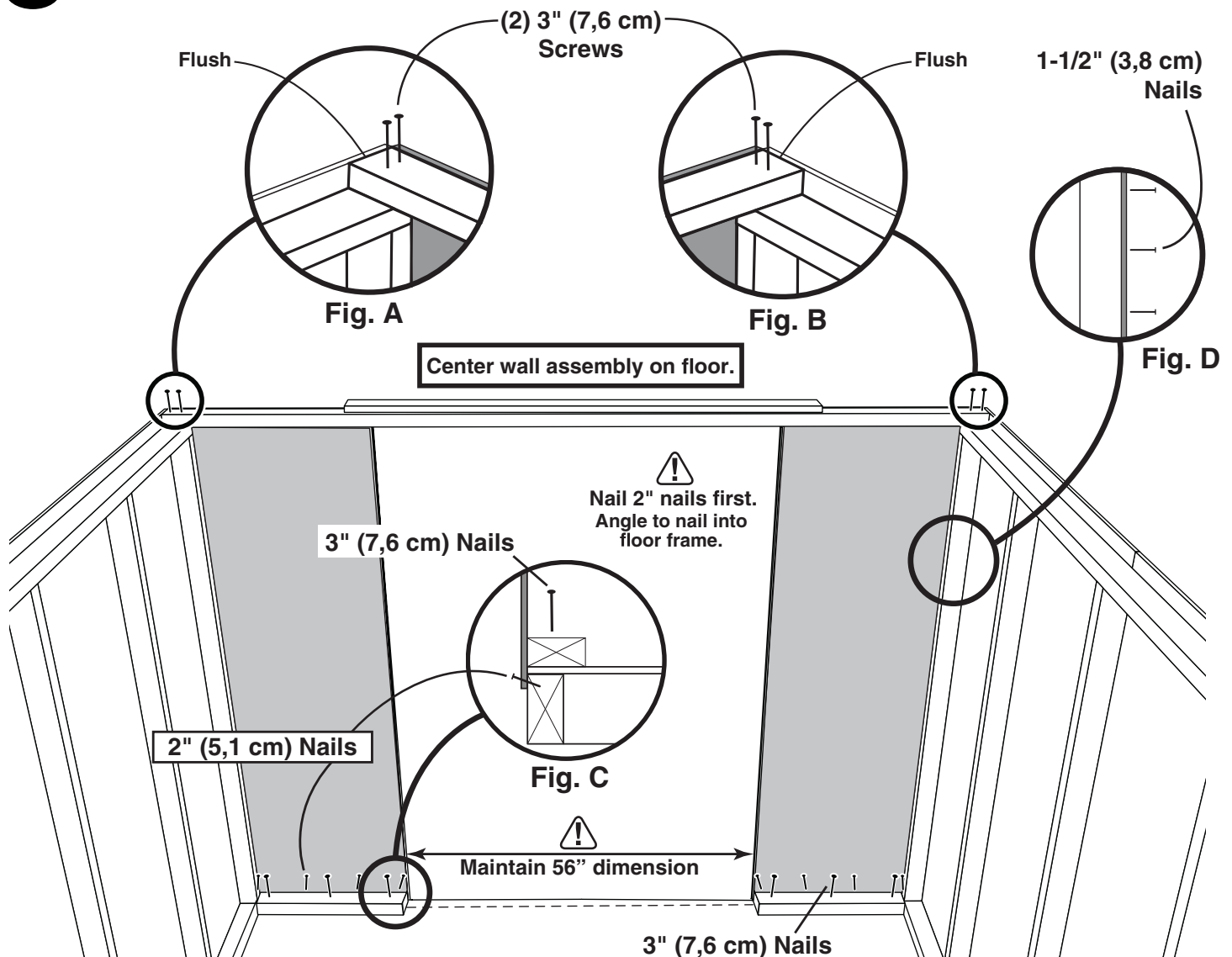

RAFTERS

PARTS REQUIRED:

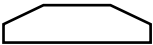
x6  6 x 24" (15,2 x 61 cm)

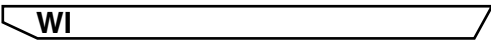
x6  **WI**
2 x 4 x 54-1/16" (5,1 x 10,2 x 129,8 cm)

x1  **OO**
2 x 3 x 69" (5,1 x 7,6 x 175,3 cm)
TEMPORARY SUPPORT

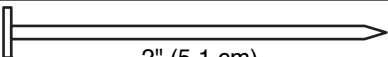
x72  2" (5,1 cm)



✓ BEGIN

- 1** You will build **THREE** assemblies;
Place two rafter-halves **WI** in the corner of back and side walls.
Rafters contact at peak.



HINT:
Use floor and walls to help assemble rafters!

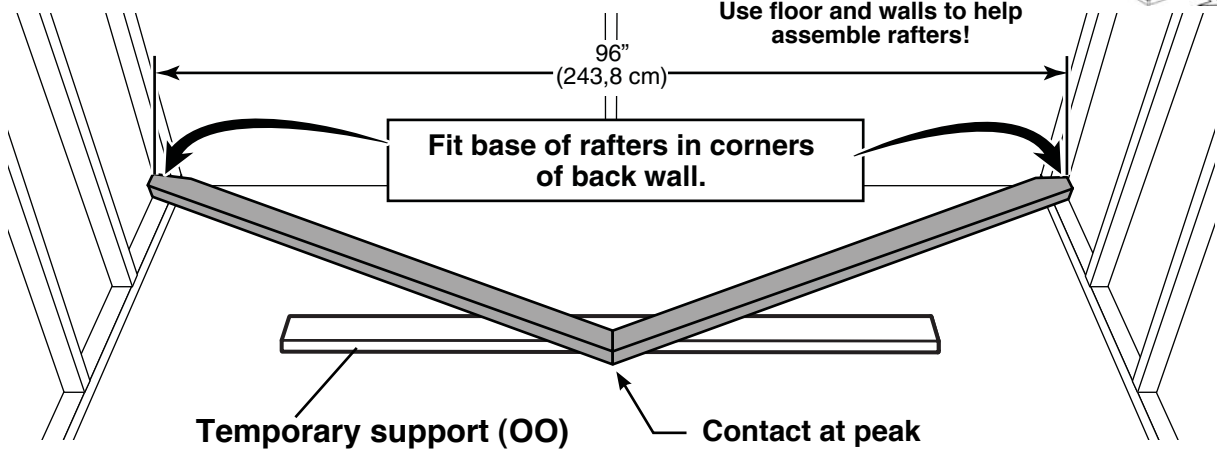

- 2** Apply glue to rafters where the gusset will fit.
- 3** Nail gusset to rafters using twelve 2" nails in pattern shown.
- 4** Flip over rafter assembly and repeat **STEPS 2-3** to attach second gusset to other side.
- 5** Repeat **STEPS 1-4** to build **TWO** additional rafter assemblies.

FINISH

- 6** You have finished assembling your rafters.

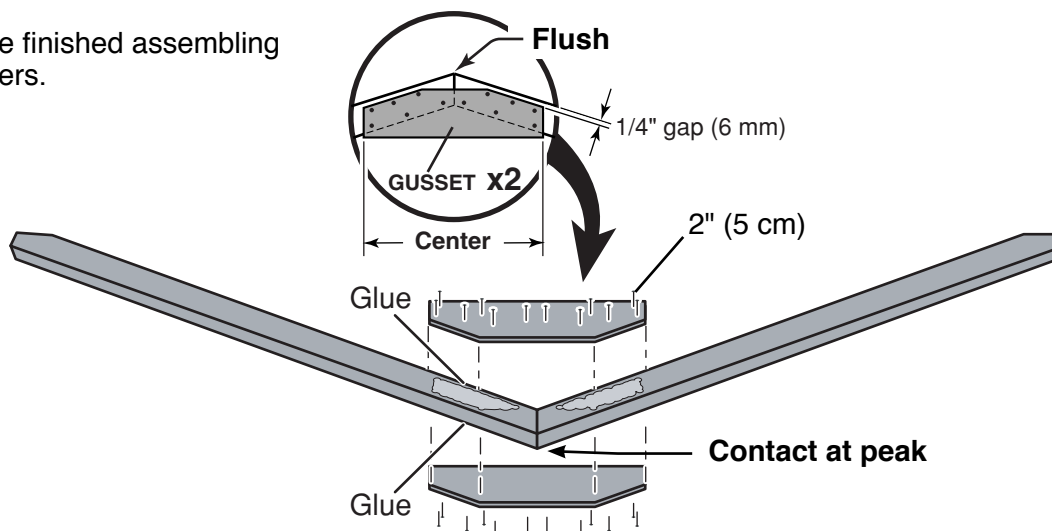

RAFTERS

PARTS REQUIRED:

x12 3" (7,6 cm)

x6 2" (5,1 cm)

x3 PRE-ASSEMBLED

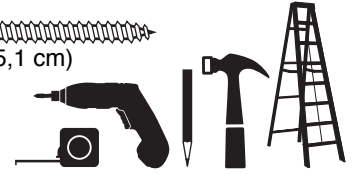

✓ BEGIN

1 Locate rafters directly over the wall studs. Ensure you have the measurements shown.



2 Screw through panel into end of rafter with 2" screw (Fig. A).

3 Secure with two 3" screws angled at each end (Fig. B).



FINISH

4 You have finished installing your rafters.

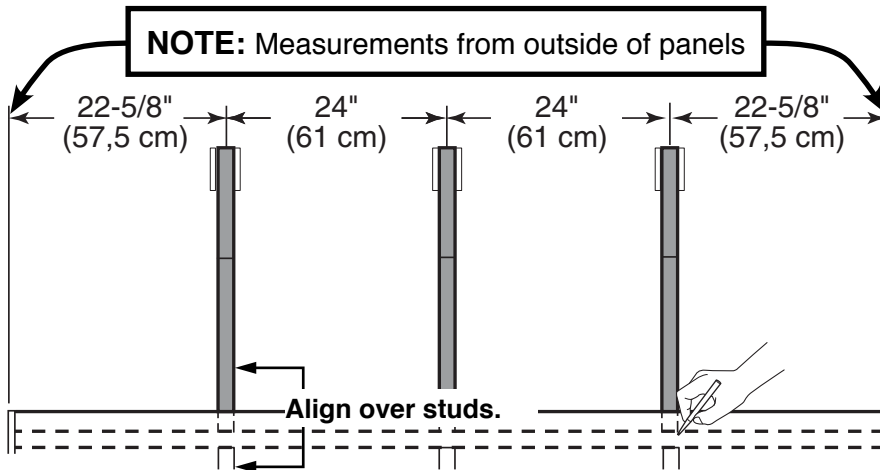

⚠ Maintain the measurements between rafters.

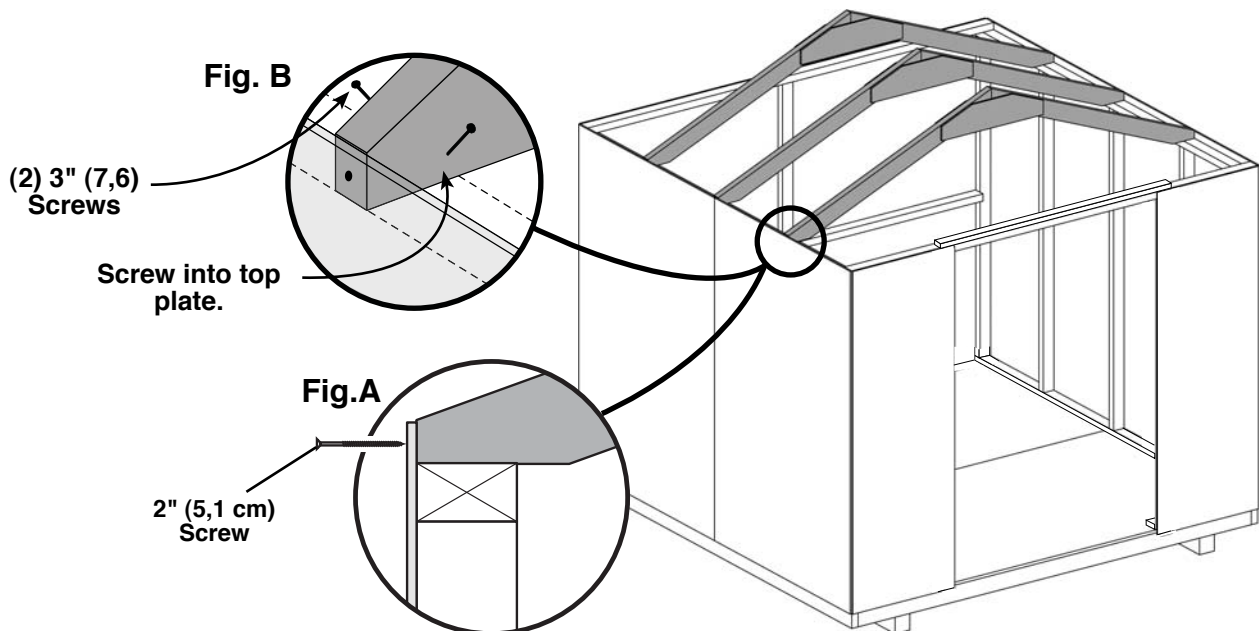

BACK WALL GABLE PANELS

PARTS REQUIRED:

x1 **LW** 2 x 3 x 23-7/8" (5,1 x 7,6 x 60,6 cm)

x10 1-1/2" (3,8 cm)



✓ BEGIN

- 1 Place **LW** on flat on floor.
- 2 Place **RIGHT** gable panel primed side up, centered on **LW** with a 3/4" overhang on bottom. Nail using five 1-1/2" nails, 6" apart.
- 3 Place **LEFT** gable panel primed side up, flush to right panel on **LW** with a 3/4" overhang on bottom. Nail using five 1-1/2" Nails, 6" apart.



FINISH

- 4 You have finished building your back wall gable panels.

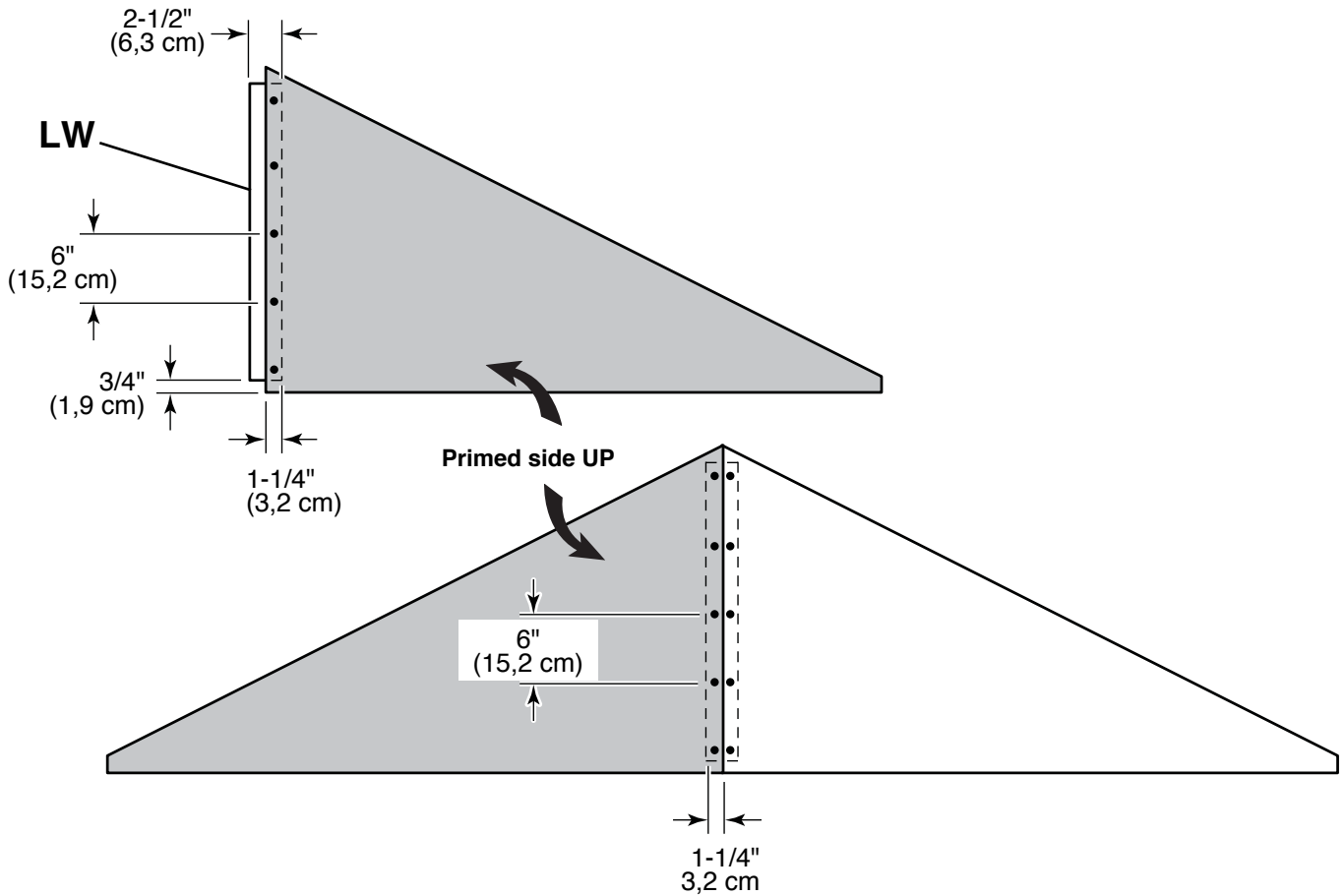

BACK WALL GABLE PANELS

PARTS REQUIRED:



PRE-ASSEMBLED

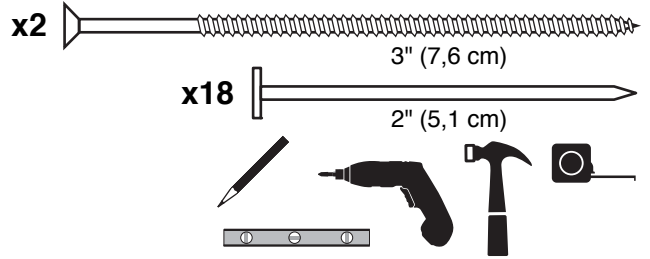

✓ BEGIN

- 1 Place gable assembly centered on back wall top plate overlapping the back wall panels 3/4" (Fig. A).
- 2 Nail assembly to back wall panels using 2" nails 6" apart.
- 3 Screw LW to top plate using two 3" screws (Fig. B).



FINISH

- 4 You have finished installing your back wall gable panels.

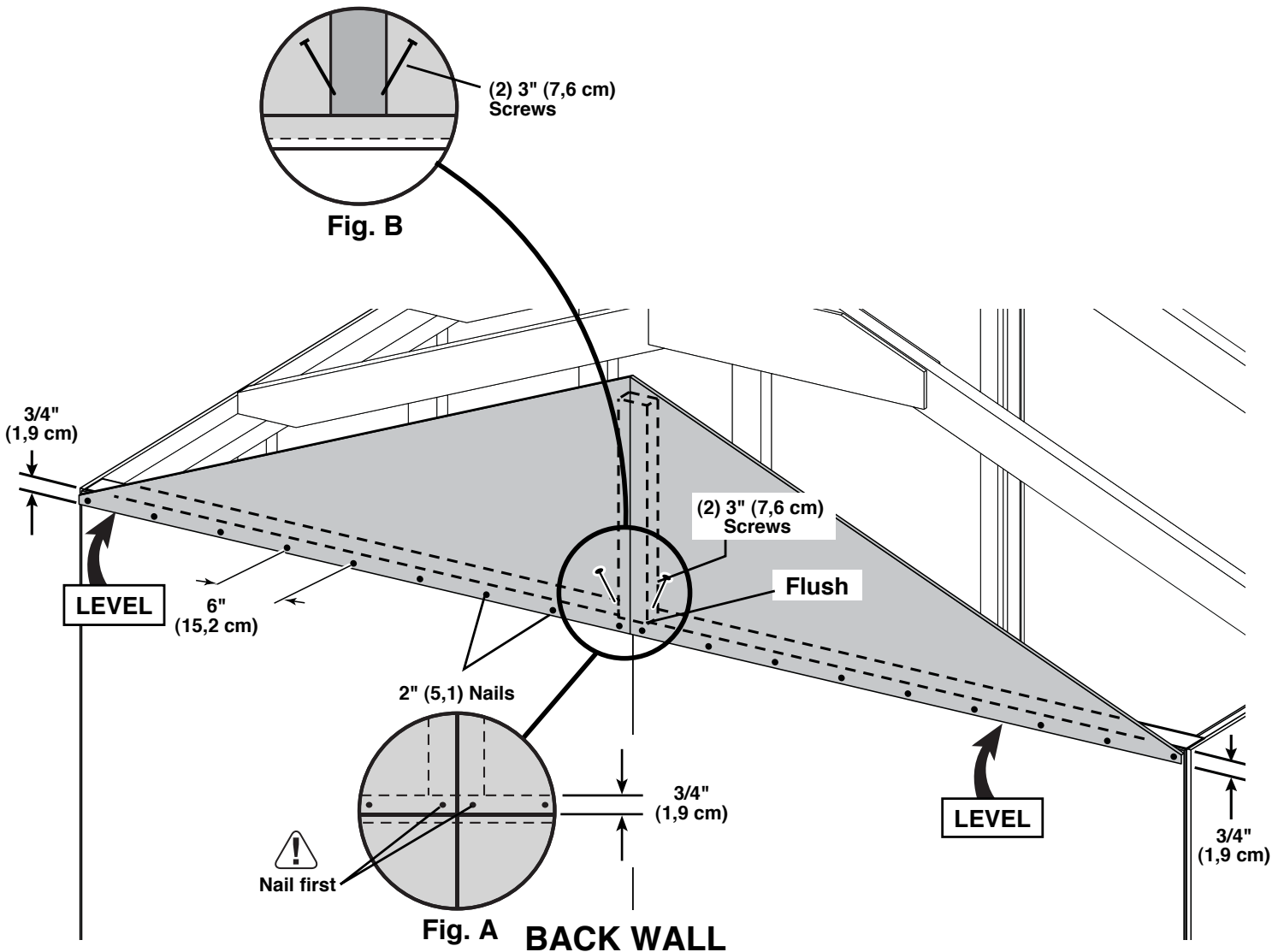

FRONT WALL GABLE PANELS

PARTS REQUIRED:

x2 **DQ** 2 x 3 x 11-7/8" (5,1 x 7,6 x 30,2 cm)

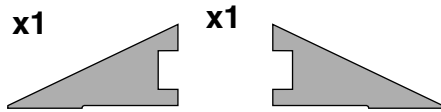

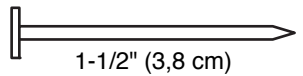
x8  1-1/2" (3,8 cm)



✓ BEGIN

- 1 Place **DQ** on flat on floor as shown.
- 2 Place **RIGHT** gable panel primed side up, centered on **top DQ** as shown. Secure using two 1-1/2" nails.
- 3 Orient **LEFT** gable panel primed side up, flush to right panel on **DQ's** with a 1-1/2" overhang on bottom. Nail using four 1-1/2" Nails.



- 4 You have finished building your Front wall gable panels.

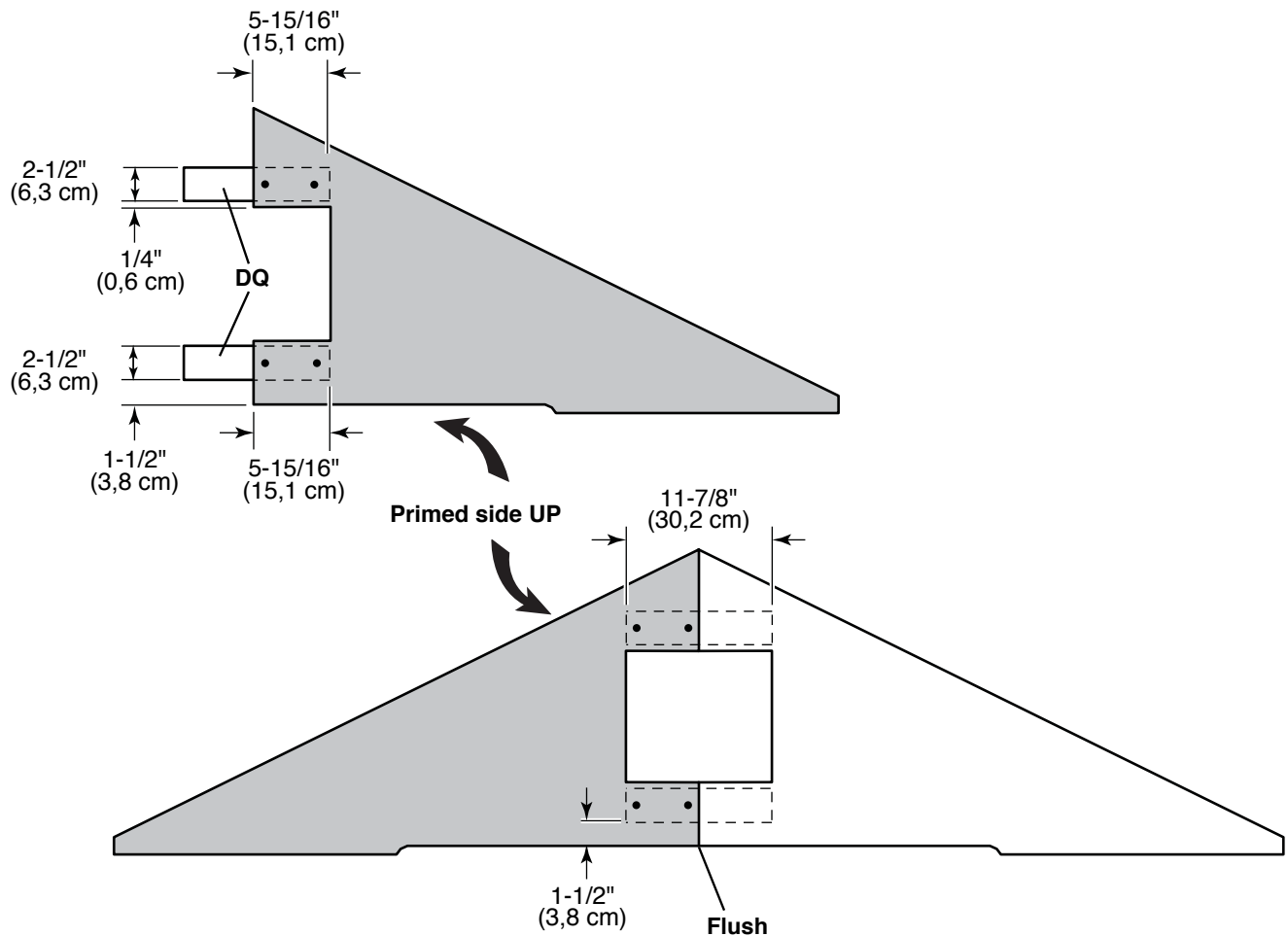

WINDOW INSTALL

PARTS REQUIRED:

x1

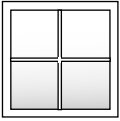

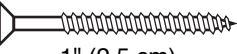
x2  1" (2,5 cm)

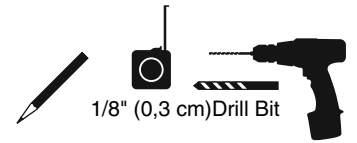

1/8" (0,3 cm) Drill Bit

✓ **BEGIN**

- 1 Center window in window opening as shown. **Make sure frame is at an equal distance from bottom of panel (Fig. A).**
- 2 Secure window to **DQ** using one screw in top and bottom (**Fig. B**).

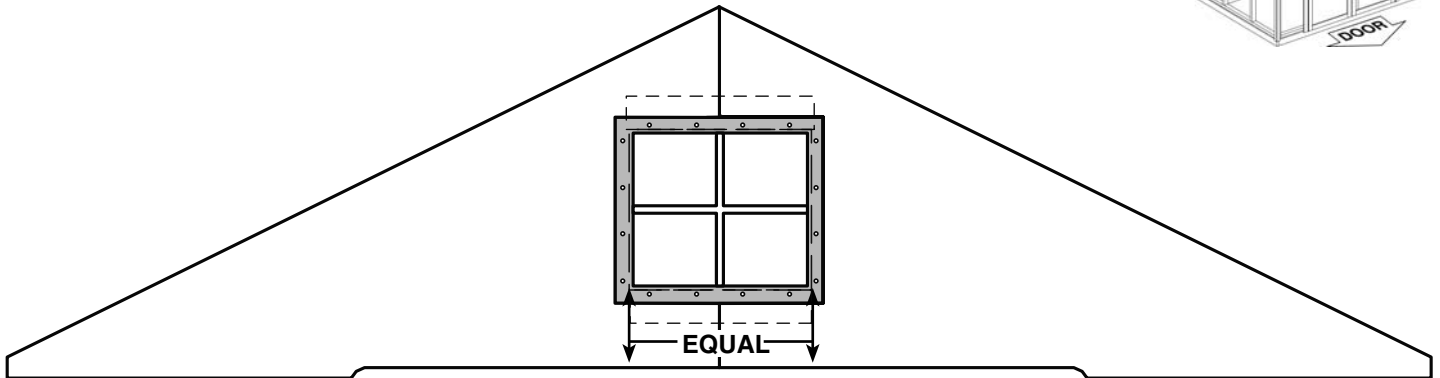

Fig. A

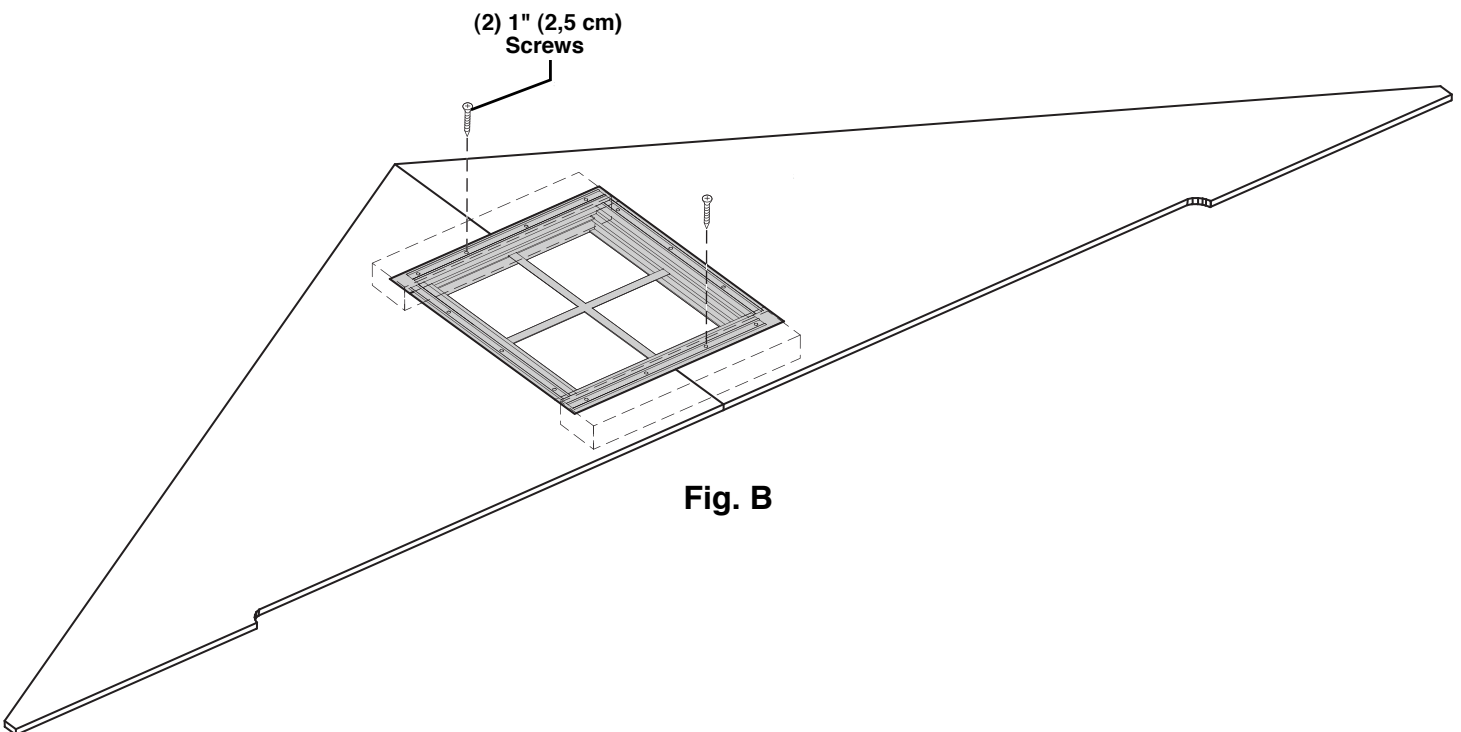



Fig. B

WINDOW INSTALL

PARTS REQUIRED:

x2  WQ 1 x 2 x 11" (2,5 x 5,1 x 27,9 cm)

x2  WO 1 x 2 x 14" (2,5 x 5,1 x 35,6 cm)

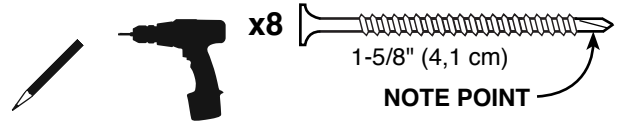

NOTE POINT

✓ BEGIN

1 Center window trim on window.
NOTE: There will be a slight reveal inside window.

2 Secure window trim using self-drilling 1-5/8" screws through window flange (**Fig. A**)

FINISH

3 You have finished installing your window trim.

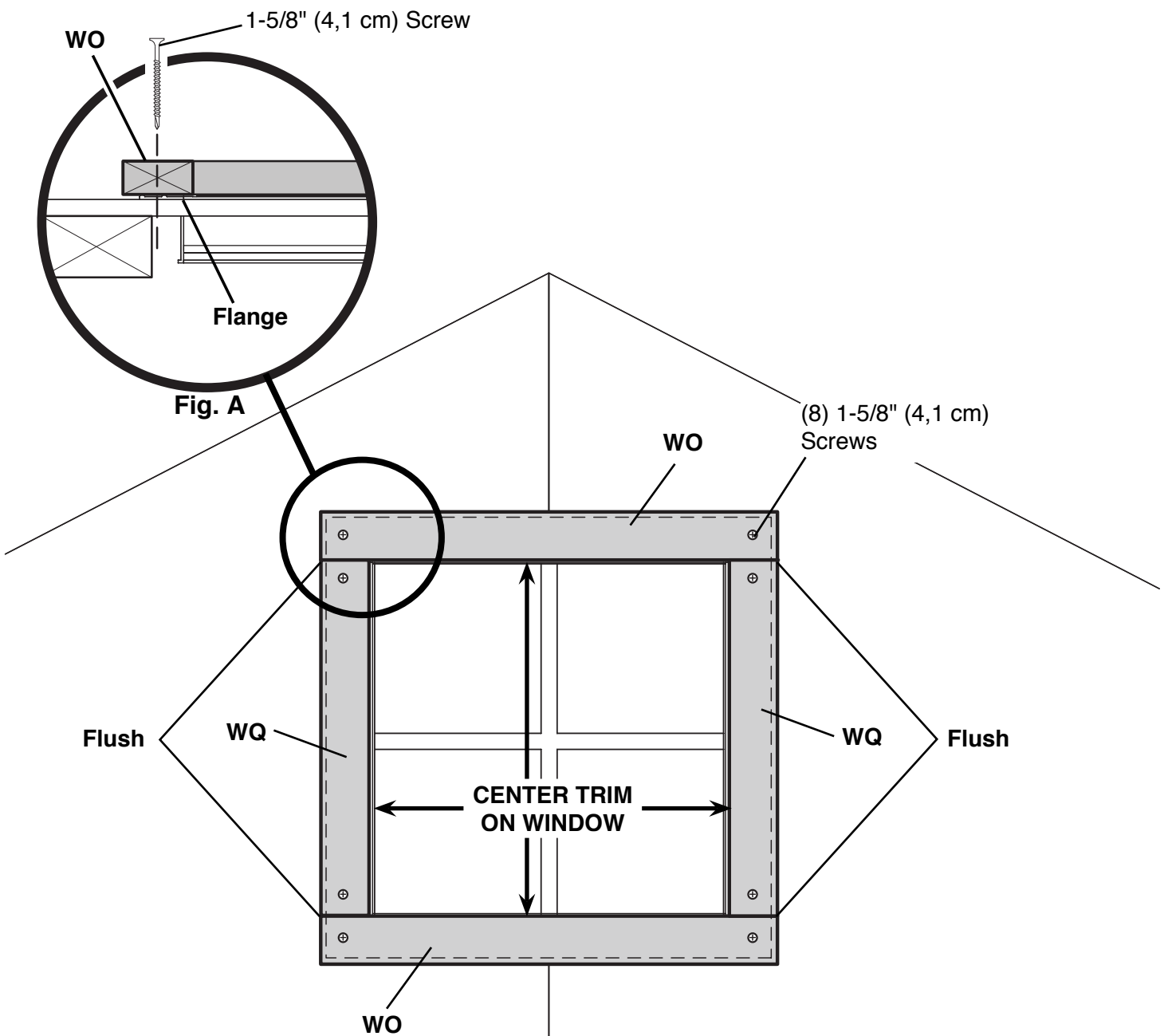

FRONT WALL GABLE PANELS

PARTS REQUIRED:

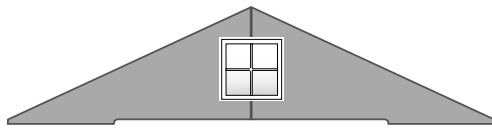

PRE-ASSEMBLED

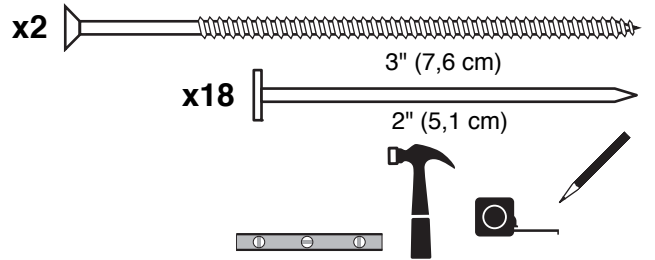

✓ BEGIN

- 1 Place gable assembly centered on front wall top plate overlapping front wall panels.
- 2 Screw **DQ** to top plate using two 3" screws (**Fig. A**).
- 3 Nail gable panels to front wall panels and **LW** using 2" nails, 6" apart.



FINISH

- 4 You have finished installing your front wall gable panels.

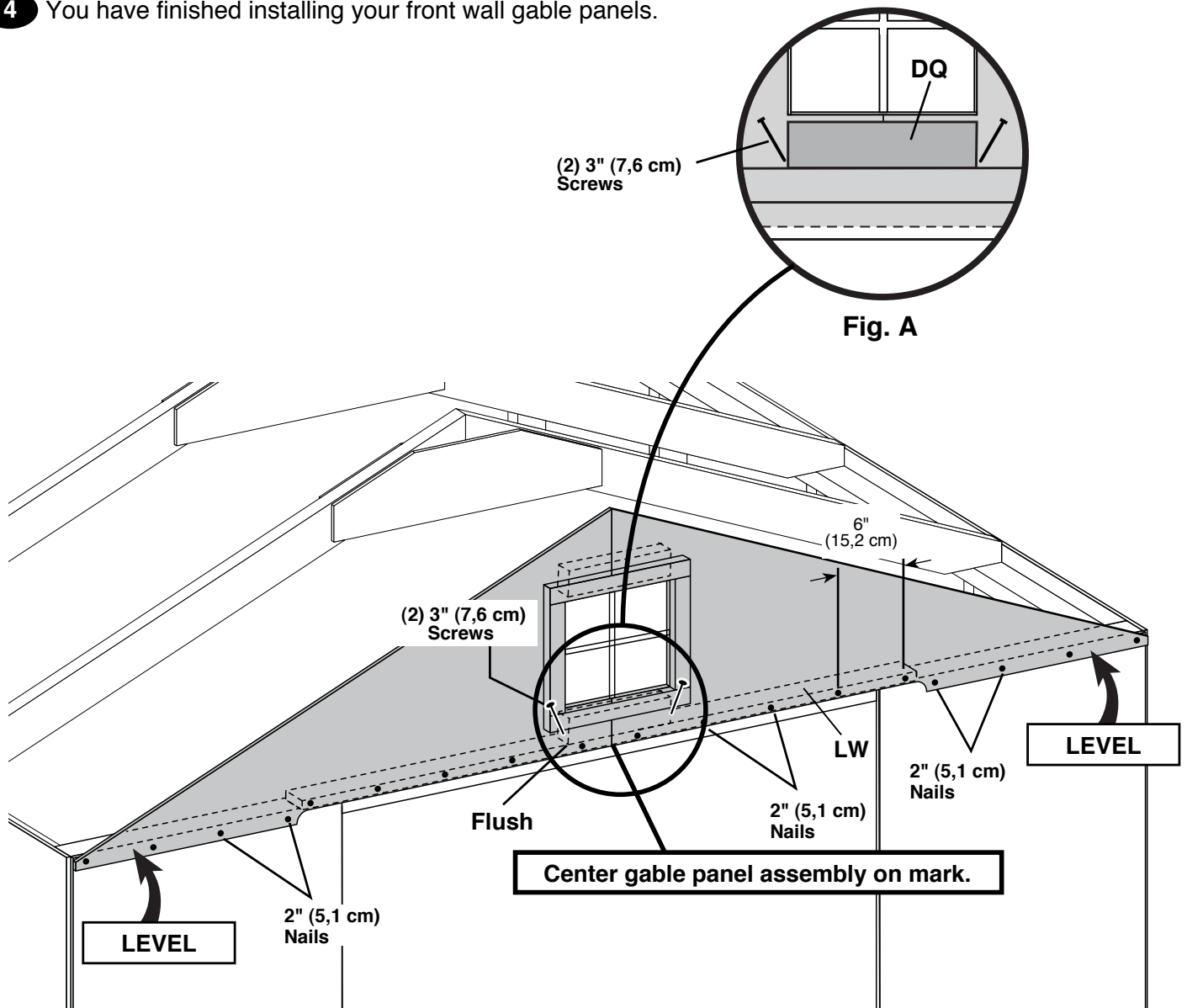

GABLE TRIM

PARTS REQUIRED:

x4 **WX**
2 x 3 x 55-3/4" (5,1 x 7,6 x 141,6 cm)

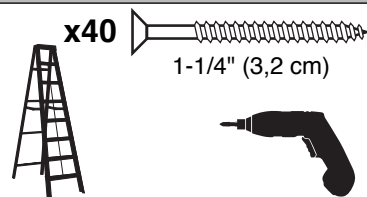

✓ BEGIN

- 1 Install front gable trim **WX** flush to top edge of panel and flush at peak (**Fig. A**) as shown.
- 2 Attach trim to wall using 1-1/4" screws 7-1/4" apart. Screw through panels into **WX**.
- 3 Repeat above **steps 1-2** to secure back wall gable trim.



FINISH

- 4 You have finished installing your gable trim.

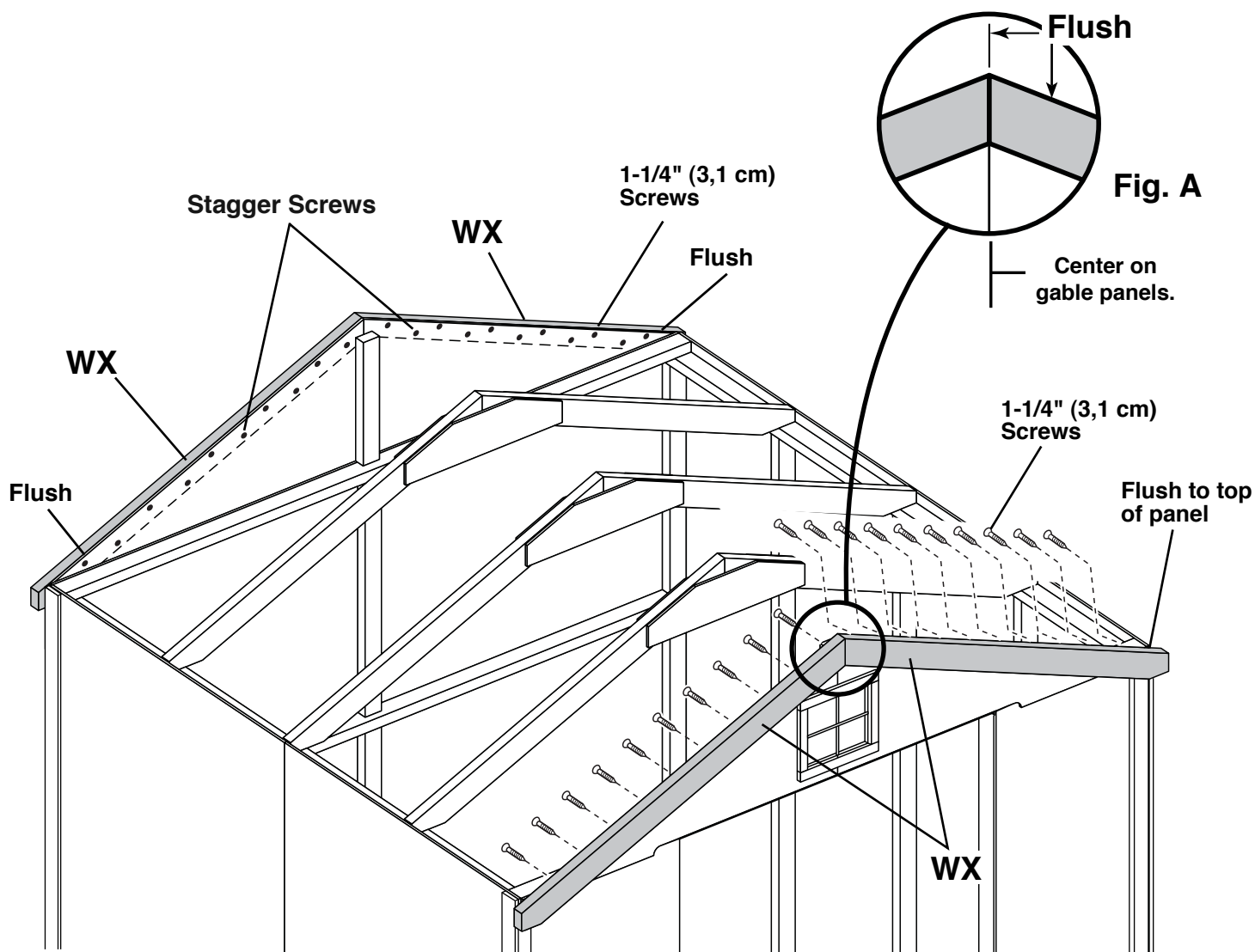

ROOF PANELS

PARTS REQUIRED:

x2



7/16 x 48 x 96"
(1,1 x 121,9 x 243,8 cm)

x8 2" (5,1 cm)



Roof panels may cause serious injury until securely fastened.



You must square the roof by attaching one panel first. You will use the panels' long edge as a lever to bring your roof into square. Commonly known as "racking".

✓ BEGIN

- 1 Attach the **48 x 96"** panel with the rough side up (painted-grid lines side) with a $1/2"$ measurement on the gable trim (**Fig A**) and the panel flush at the peak (**Fig. B**).

Secure panel with two 2" nails in the corners.

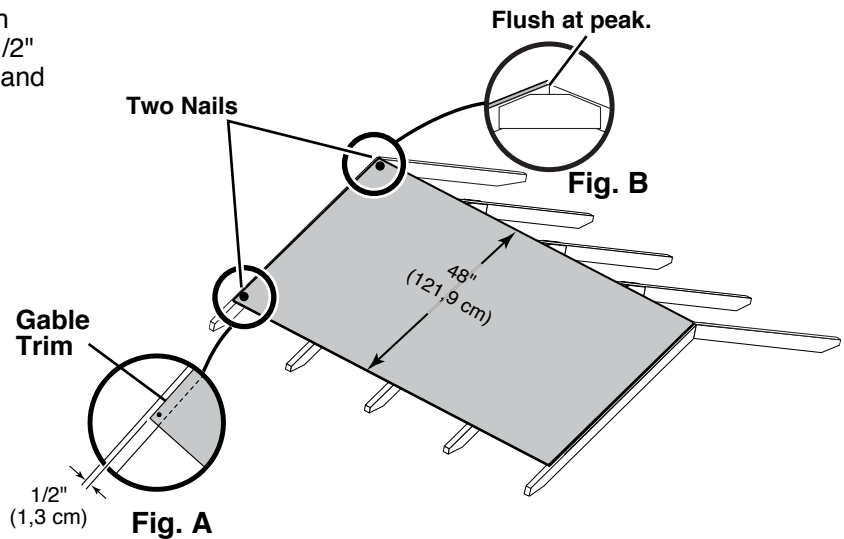

- 2 Move to the opposite end. Using the long edge of the panel as a lever move the panel side-to-side until the top corner is flush to the peak (**Fig. C**) and there is a $1/2"$ measurement to the gable trim (**Fig. D**).

You may need to move your backwall to get the $1/2"$ measurement. Secure panel with two 2" nails in the corners.

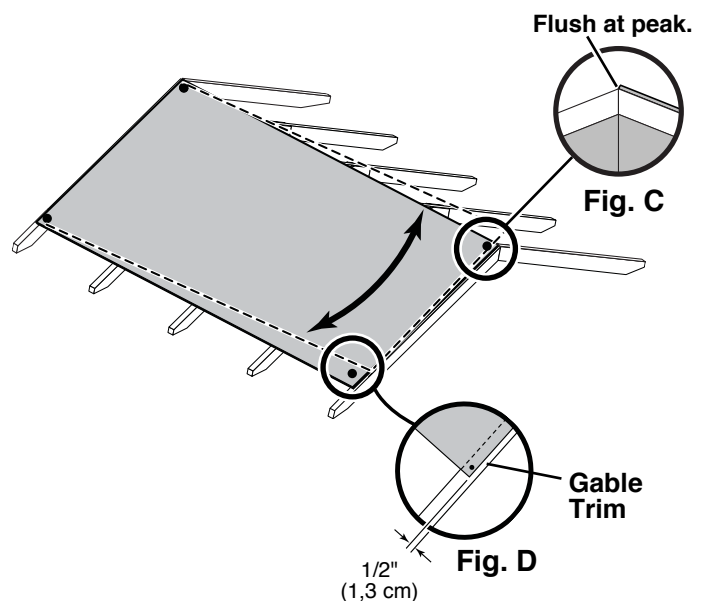

ROOF PANELS

PARTS REQUIRED:

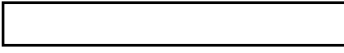
x2  7/16 x 7-7/8" x 96"
(1,1 x 20 x 243,8 cm)

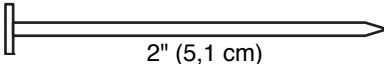
x86  2" (5,1 cm)

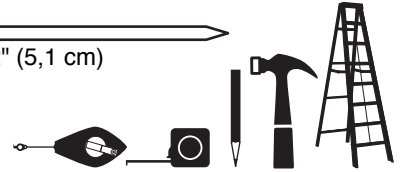

3 Keep spacing between the center of the rafters at the lower edge of the panel and secure with one 2" nail into each rafter (**Fig. E**).

Move to the top of the panel and keep spacing between the center of the rafters. Secure with one 2" nail into each rafter (**Fig. E**).

Nail the roof panel using 2" nails 6" apart on edges and 12" apart inside panel (**Fig. F**).

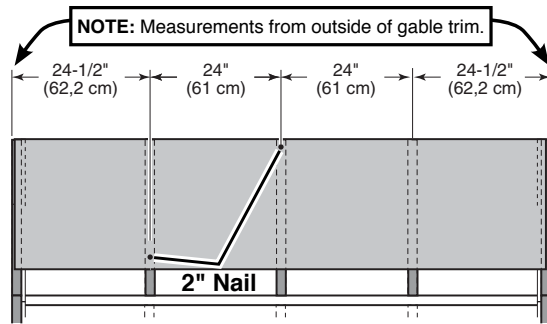

Fig. E

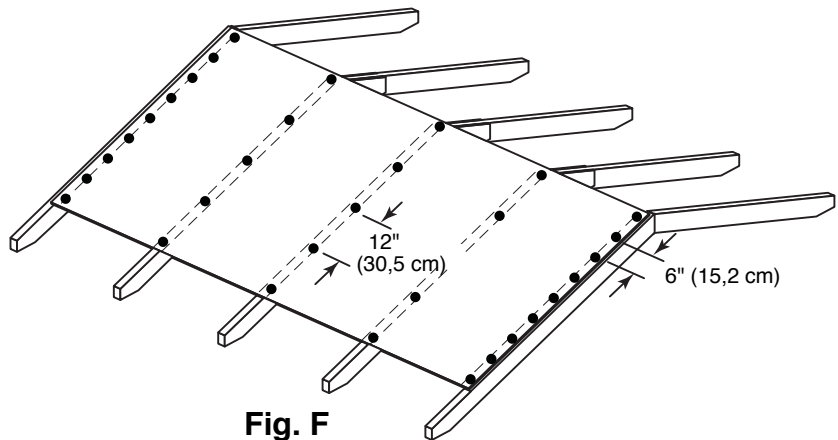

Fig. F

4 Attach the lower roof panel flush to the upper panels and with a 1/2" measurement at the gable trim (**Fig. G**).

Nail the roof panel using 2" nails 6" apart on edges and 12" apart inside panel.

Repeat process to attach roof panels on the opposite side.

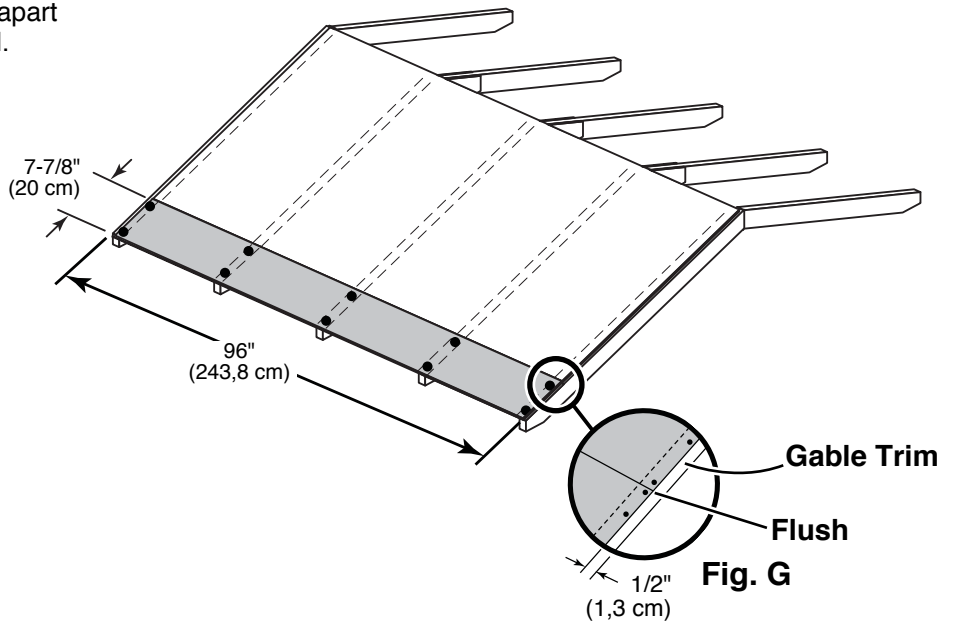
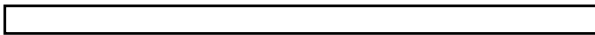
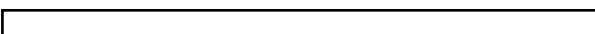
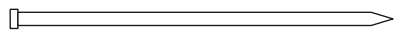

Fig. G

TRIM

PARTS REQUIRED:

- x4 
3/8 x 1-3/4 x 71-1/4" (1 x 4,4 x 181 cm)
- x4 
3/8 x 1-3/4 x 71-3/4" (1 x 4,4 x 182,2 cm)

x56  2" (5,1 cm)

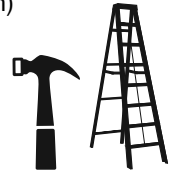

✓ BEGIN

- 1 Attach **71-3/4"** trim flush to back of gable trim and bottom of roof panel and trim (**Fig. A**) using 2" (5,1 cm) finish nail as shown.
- 2 Attach **71-1/4"** trim flush to bottom of gable panel (**Fig. B**) and flush to edge of 71-3/4" trim using one 2" (5,1 cm) nail as shown.
- 3 Finish attaching trim flush to corners using seven 2" (5,1 cm) finish nails as shown.
- 4 Repeat **steps 1-3** to attach trim to all four corners.



FINISH

- 5 You have finished attaching your corner trim.

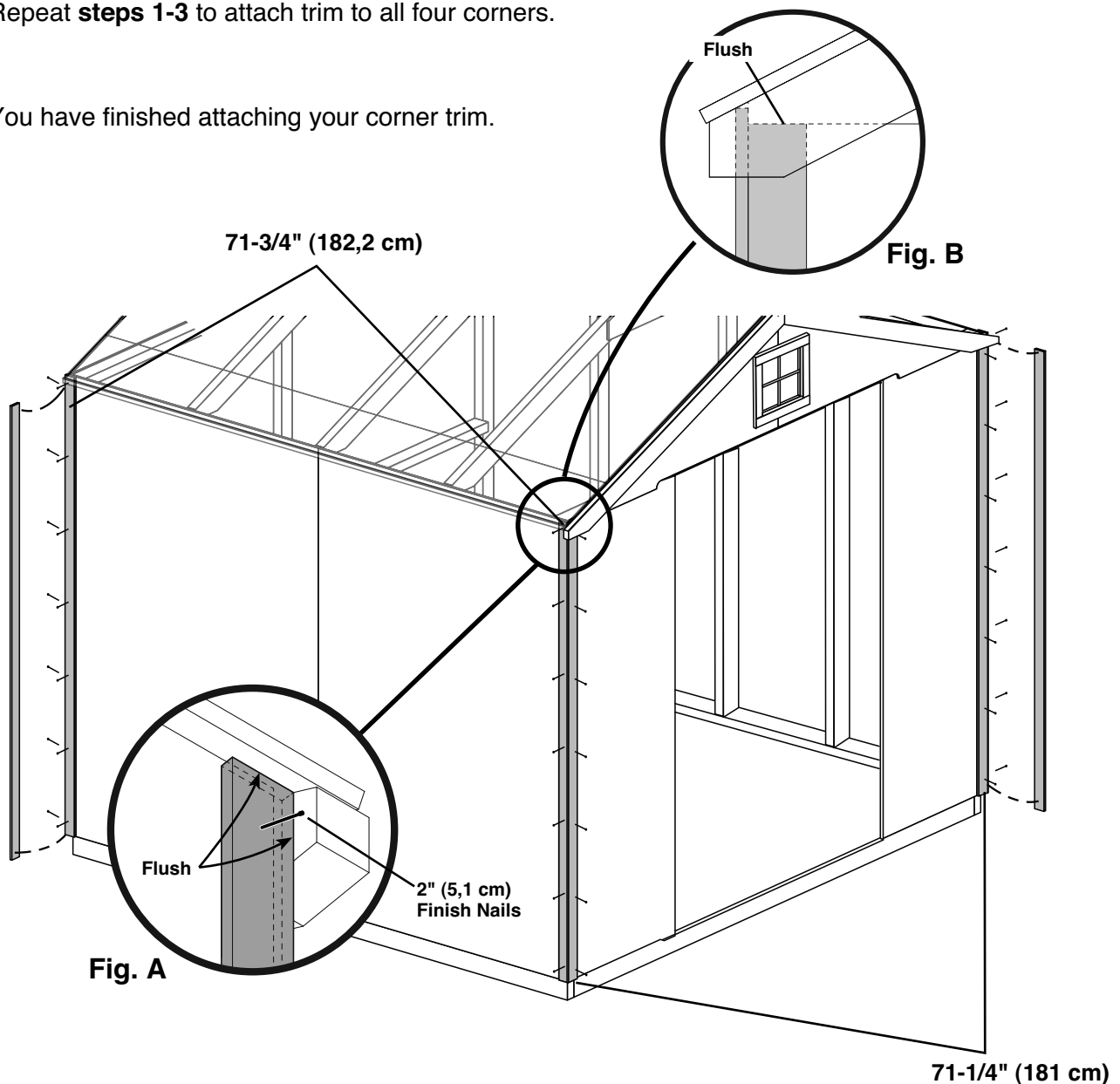

DOORS

PARTS REQUIRED:

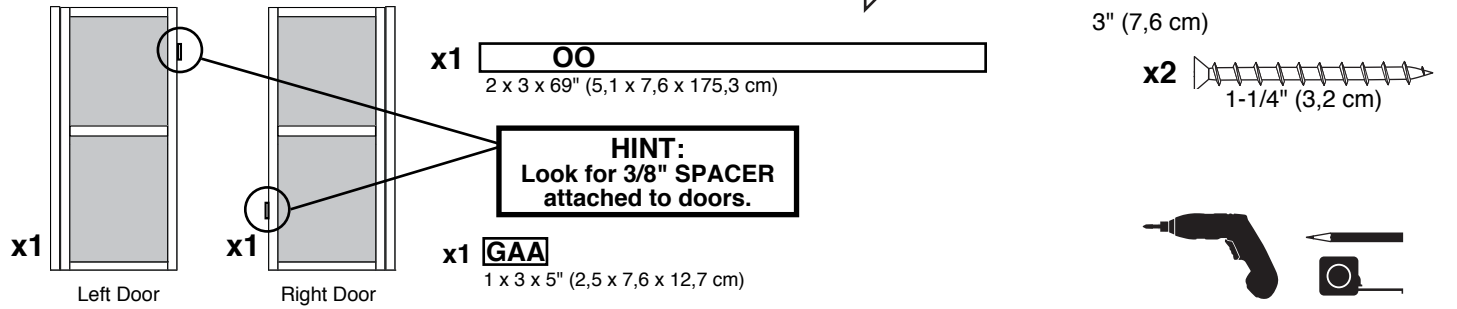

BEGIN

- 1 Orient parts as shown on flat surface. **3/8" offset is to top.** Look for red (right) and green (left) on hinge board.
- 2 Attach temporary support **OO** with 3" screws in middle and at ends as shown. Tighten securely.
- 3 Attach temporary support **GAA** with two 1-1/4" screws as shown. Tighten securely.

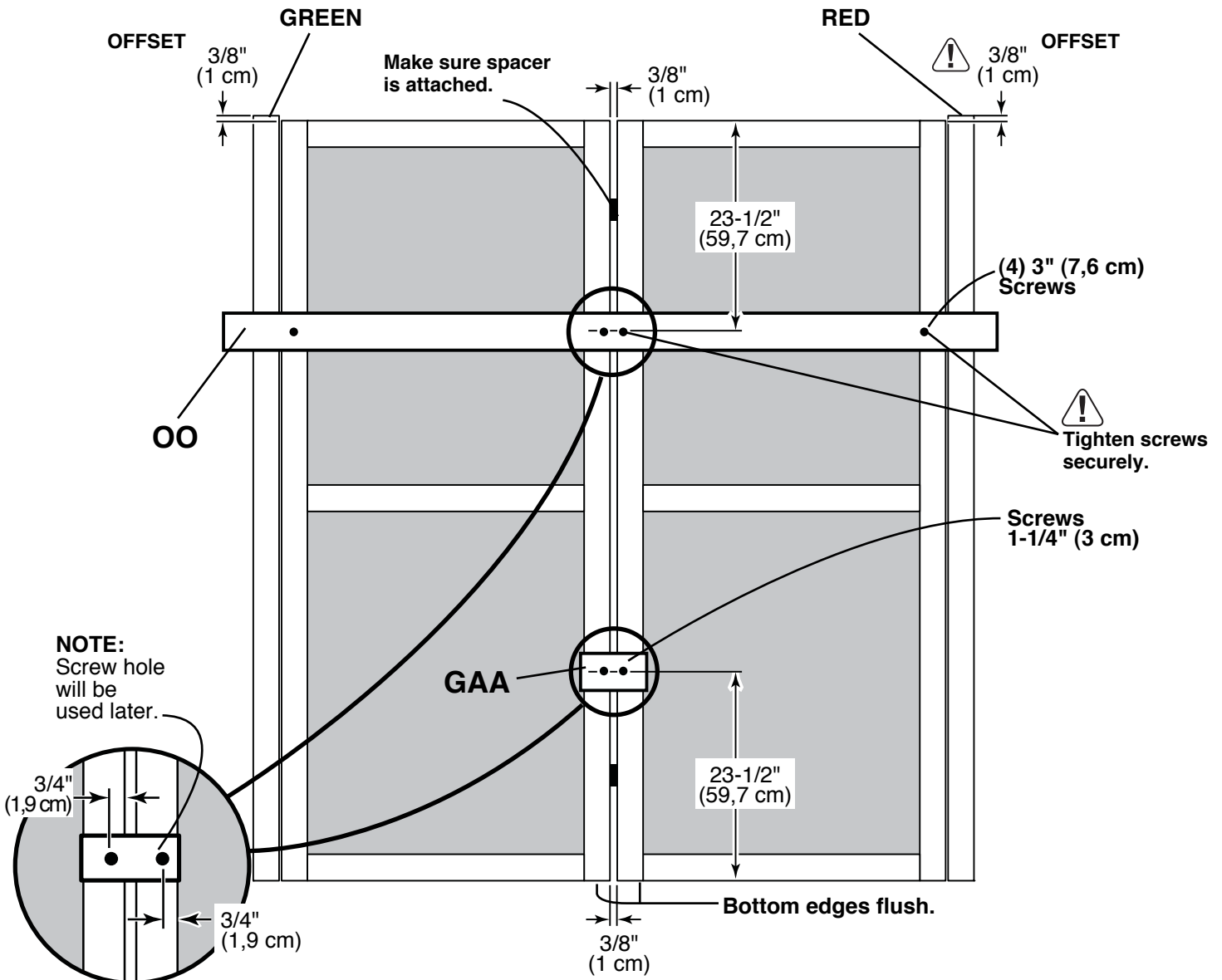

DOORS

PARTS REQUIRED:

x1 **OO**
 2 x 3 x 69" (5,1 x 7,6 x 175,3 cm)

x7  3" (7,6 cm)



- 4** Attach temporary support **OO** as a ledger board flush under wall panels for doors to rest on, using three 3" screws (**Fig. A**).

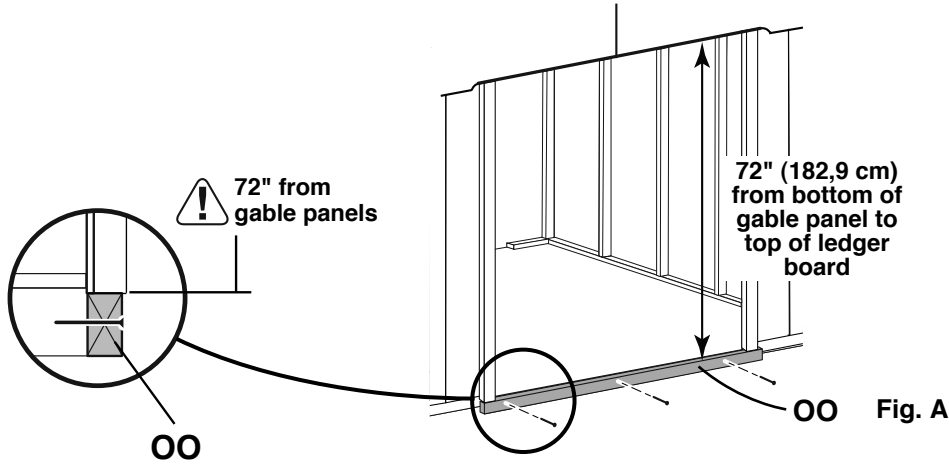

- 5** Center doors on panel seam as shown (**Fig. B**). 
 ⚠️ Check ledger board is still flush under panels.

- 6** Screw hinge boards into wall supports and floor using four 3" screws as shown.
 ⚠️ Make sure screws go into framing and floor (**Fig. C, D**).

- 7** Remove temporary supports and check doors open properly.



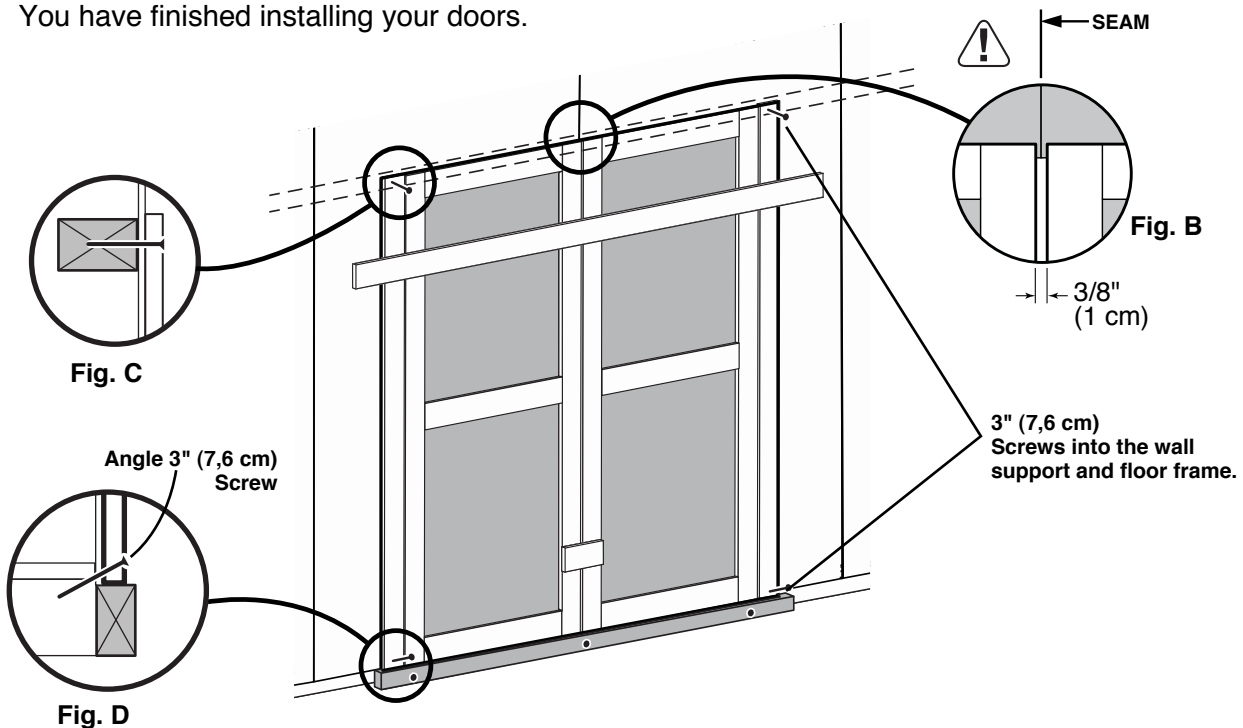

- 8** You have finished installing your doors.



DOOR

PARTS REQUIRED:

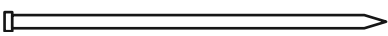
x1 **WR**
19/32 x 2-1/2 x 63" (1,5 x 6,4 x 160 cm)

x8  x58 
2" (5,1 cm) 3/4" (1,9 cm)

x10 
3/4" (1,9 cm)
Bagged separately / special coating



✓ BEGIN

- 1 Secure hinge boards from inside using 3/4" screws as shown (Fig. A).
- 2 Reinforce the door trim using 3/4" screws through door panel into trim (Fig. A). Locate screws as shown in Fig. B. Use two screws at seams.
- 3 Center trim **WR** over doors and secure using eight 2" finish nails into framing as shown.
- 4 Center metal threshold between doors and secure using ten 3/4" special coating screws into floor as shown (Fig. C).

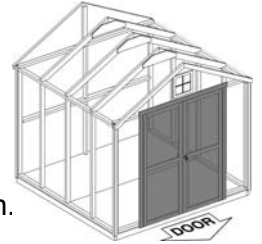

FINISH

- 5 You have finished securing your door and trim.

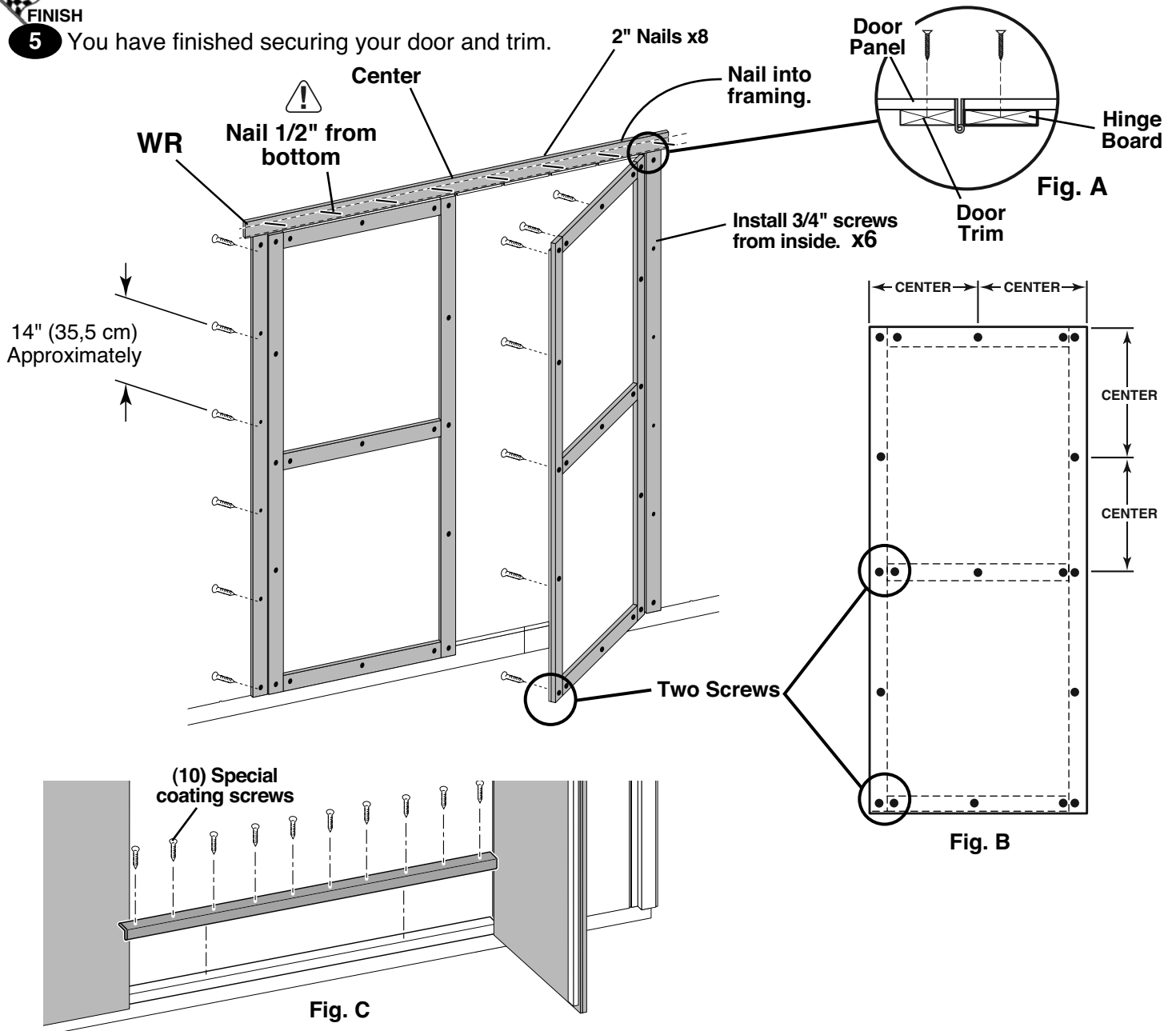

DOOR WEATHERSTRIP

PARTS REQUIRED:

x2 **OO**
2 x 3 x 69" (5 x 7,6 x 175 cm)

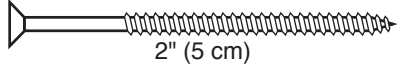
x14  2" (5 cm)



✓ BEGIN



- 1 With left door closed, center a weatherstrip **OO** vertically on the left door in the door opening (**Fig. A**). **OO** will offset the left door 1" OUT past the door trim 1" (**Fig. B**).
- 2 Secure **OO** using seven 2" screws through outside trim into **OO** (**Fig. B**)
- 3 On right door center **OO** vertically in door opening (**Fig. A**). **OO** will offset the right door 1" IN from the door trim (**Fig. C**).
- 4 Secure **OO** using seven 2" screws through outside trim into **OO** (**Fig. C**).



FINISH

- 5 You have finished installing your door weatherstrips.

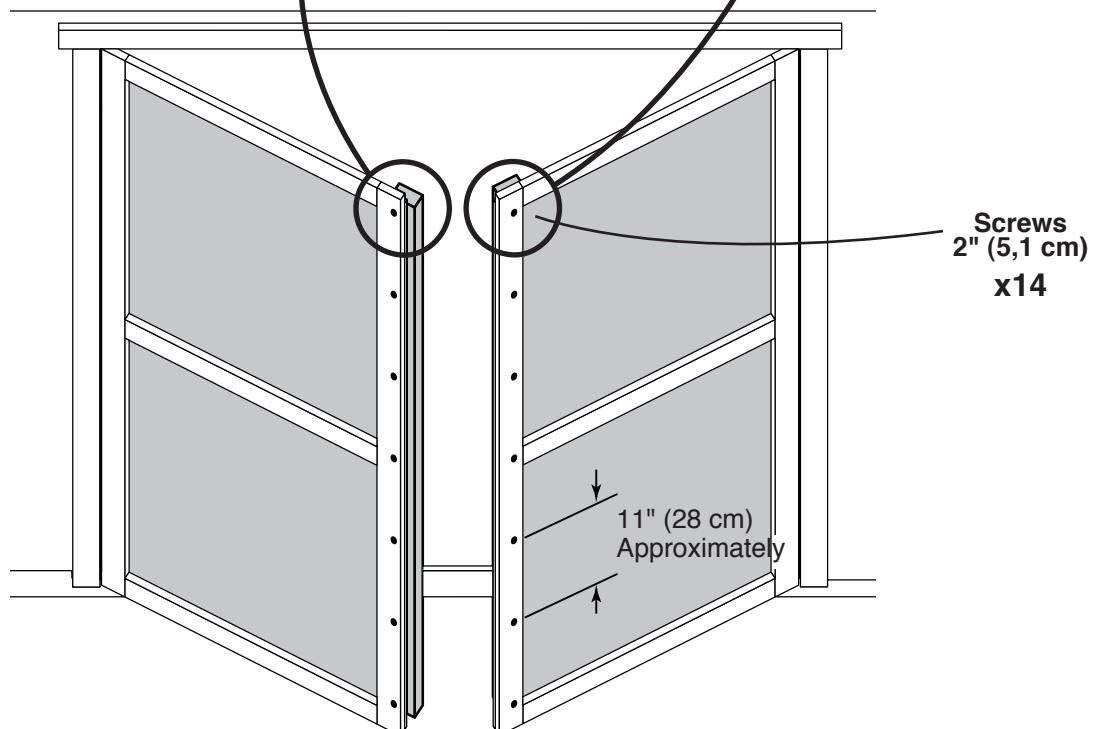
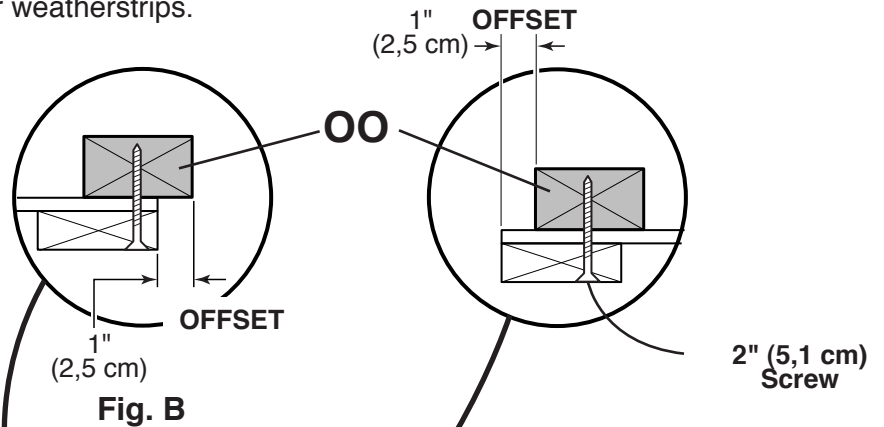
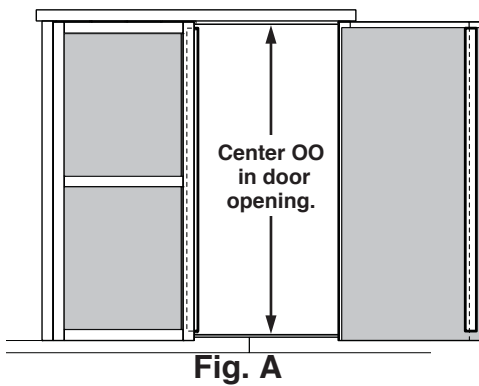

DOOR

PARTS REQUIRED:

x1

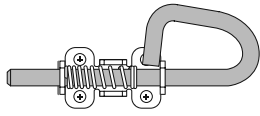

x1

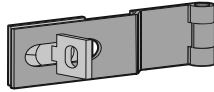

x7

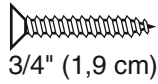

x4

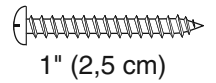

5/16" (0,8 cm) Drill Bit



✓ BEGIN

- 1 Place bolt onto **OO** in open position with bolt end 1/4" down from frame. Bolt is open when loop is contacting base (**Fig A**). Mark and pre-drill holes for screws.
- 2 Install bolt with screws supplied and drill 5/16" hole for bolt to extend into door frame.
- 3 Install hasp on right door and latch on left door. Bottom edge of hasp is 35-1/2" (90 cm) up from bottom edge of door trim. Measure and mark locations and install with 3/4" screws as shown (**Fig B**)



FINISH

- 4 You have finished mounting your door hardware.

Fig. A

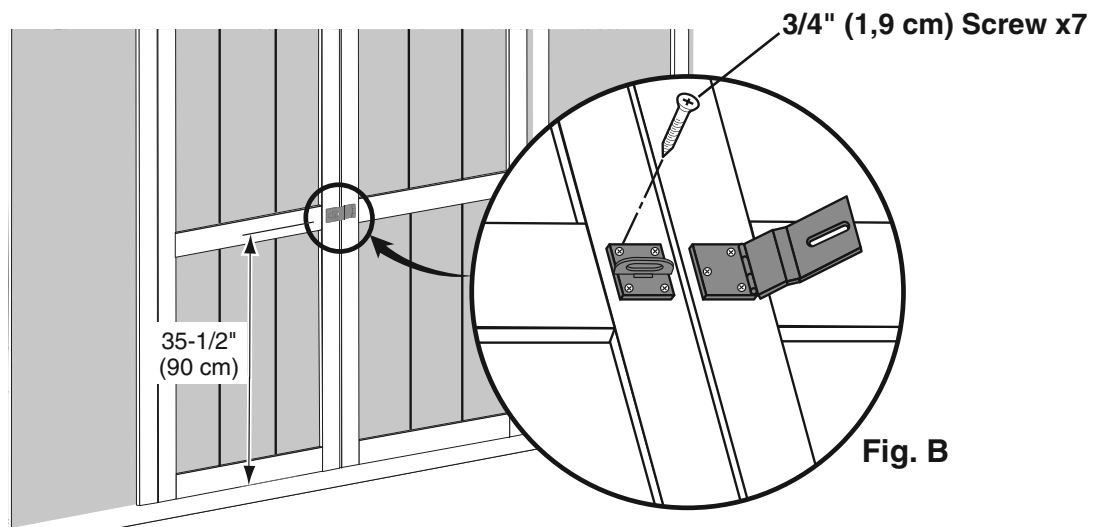
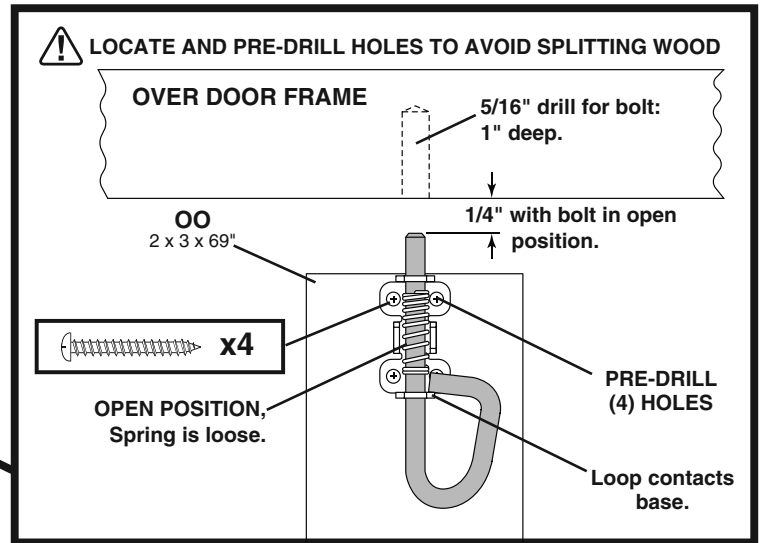
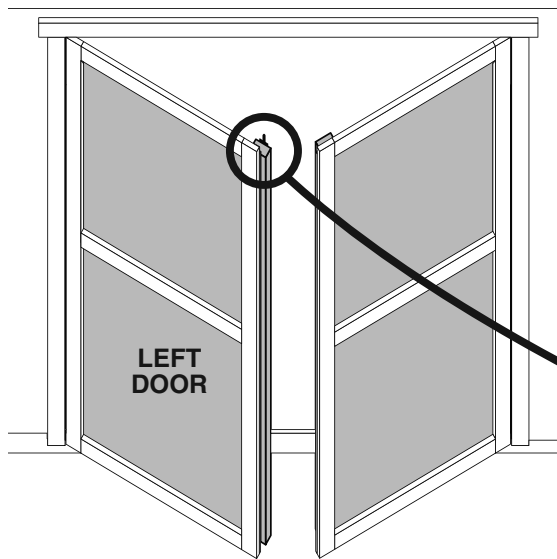

PAINT & CAULK

- NOT INCLUDED -

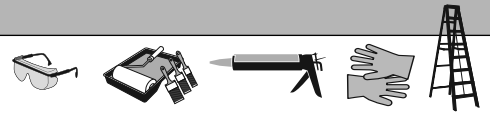

- Use acrylic latex caulk that is paintable. Caulk at all horizontal and vertical seams, between the trim and walls, and all around the door trim.
- Use a high quality exterior acrylic latex paint. When painting your building, there are a few key areas that can be easily overlooked that must be painted:
 - Bottom edge of all siding and trim
 - Inside of doors and all 4 edges

Note:

Prime all un-primed exterior wood before painting.
(Follow directions provided by manufacturer.)

ROOF FELT

- NOT INCLUDED -

- Install felt flush to all roof edges overlapping 3". Use minimal amount of roofing nails to hold in place.

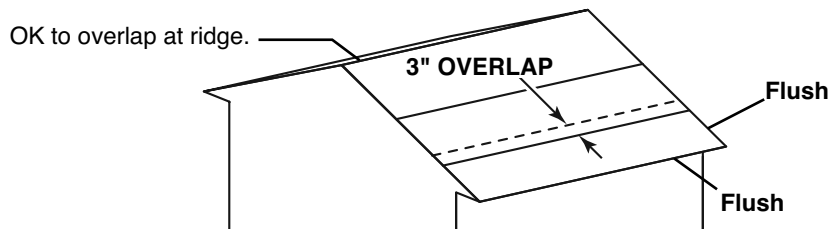

DRIP EDGE

- NOT INCLUDED -



- Install over roof felt on gable side and under roof felt on eave side (**Fig. A**).
- Do not use nails on side of drip edge that hangs over side of building.
- Only nail top of drip edge as shown.

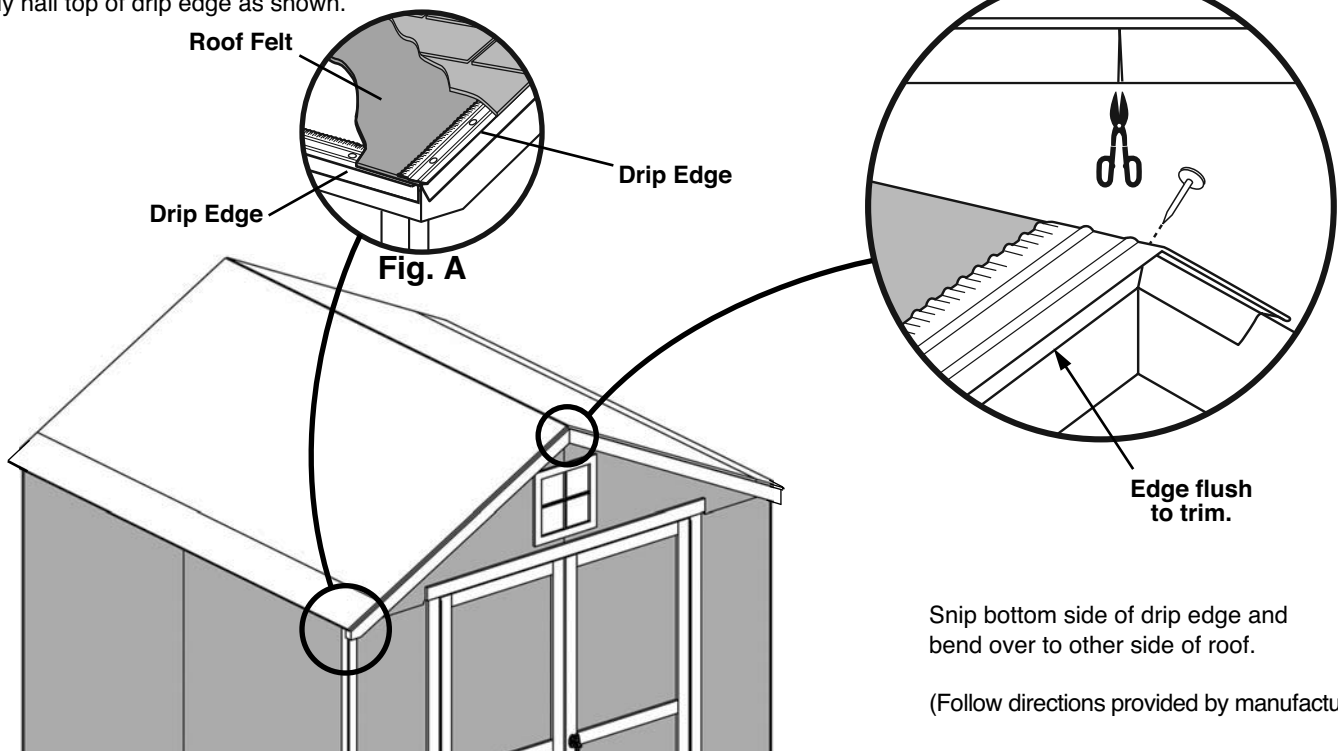

SHINGLES

- NOT INCLUDED -

• Follow directions provided by manufacturer and these instructions.

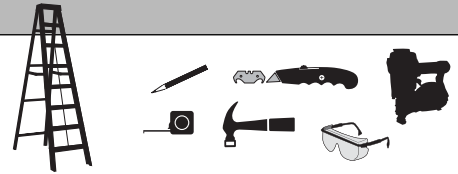

! Familiarize yourself with a 3-Tab Shingle.

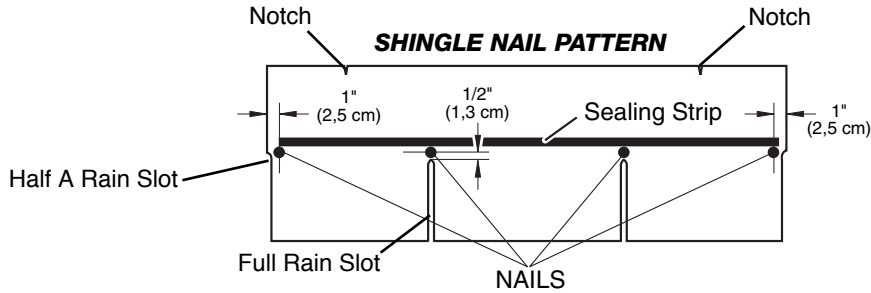

! NEVER DRIVE FASTENERS INTO OR ABOVE SEALING STRIPS.

✓ BEGIN

- 1** Install first starter row upside down and color up with a 1" overhang at back and bottom of roof panel. Use (4) nails per shingle. **Starter row must be straight and level all the way across with lower edge of roof deck.**
NOTE: If you have installed drip edge install shingles flush to drip edge.

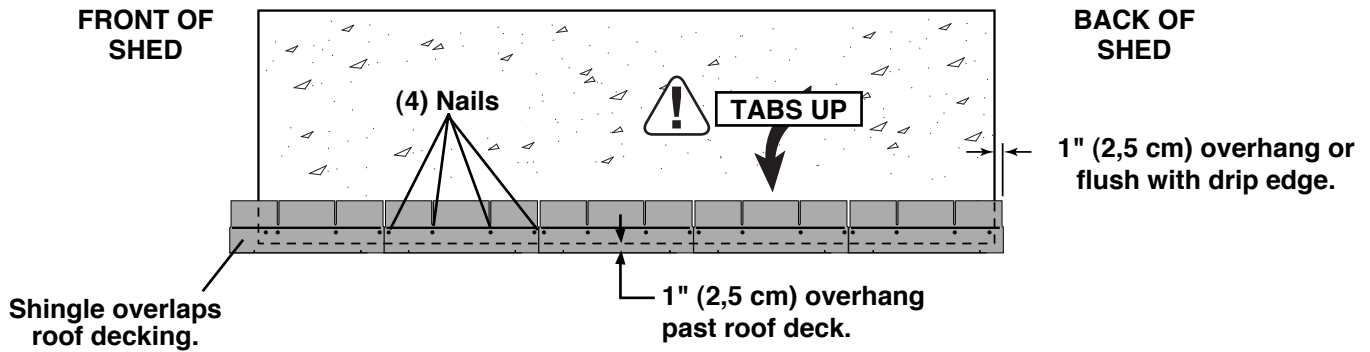

SHINGLES

continued...

- 2** Beginning at front of shed, install first row of shingles with notch at 1" past roof edge or flush with drip edge.

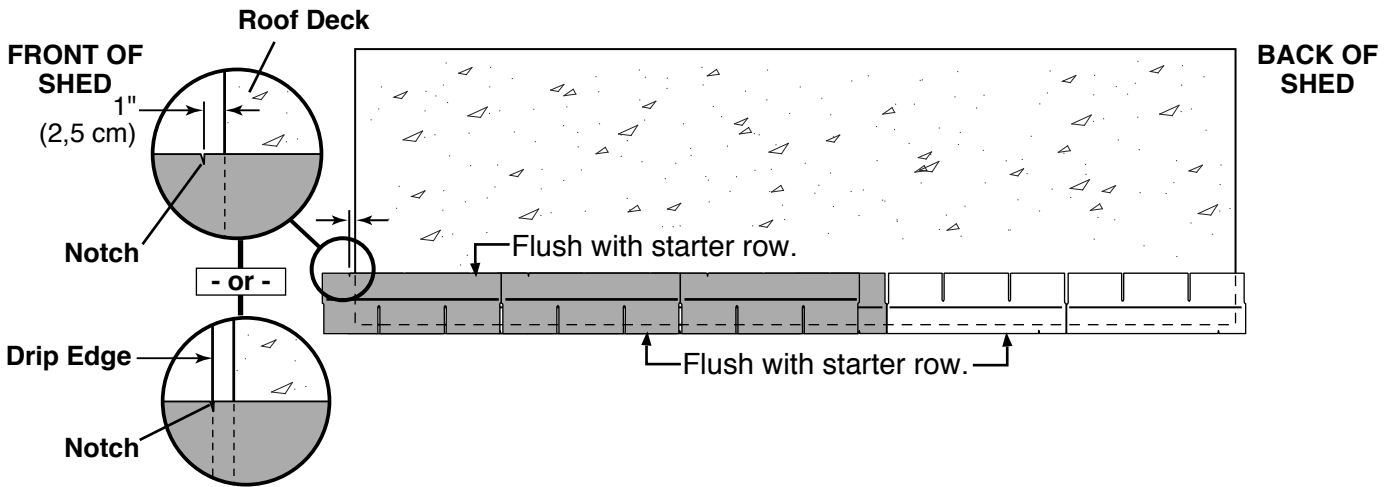

- 3** Install second row of shingles flush at top of first row's rain slots. Ensure 1" overhang or flush to drip edge at front, stagger each row.

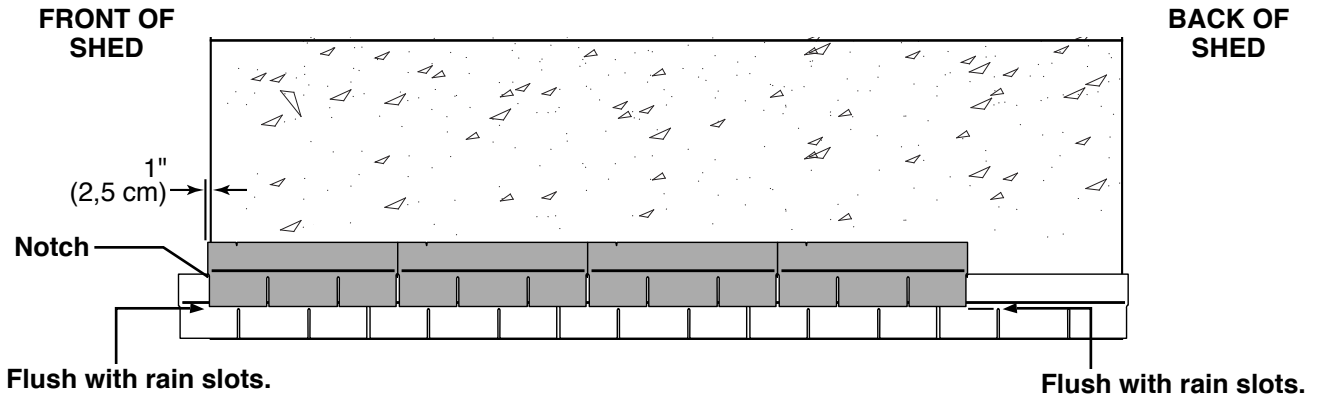

- 4** Continue installing rows of shingles by staggering at front.

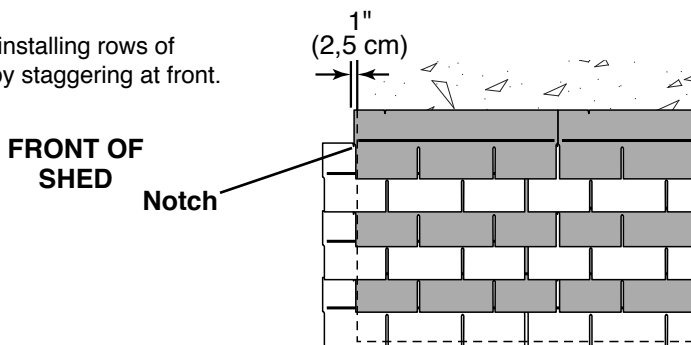

SHINGLES

continued...

- 5** Continue installing rows of shingles to the peak. At the peak make sure there is a maximum of 5" or less to the rain slot, as shown below. If shingles overlap at ridge cut to peak with a utility knife.

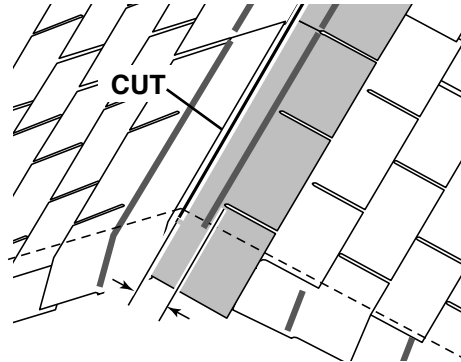
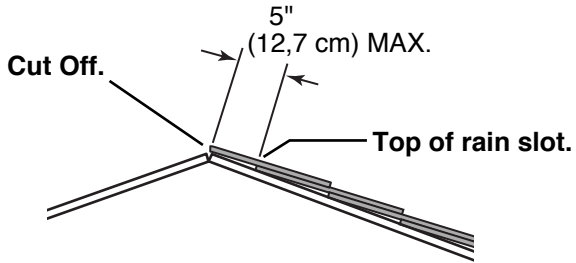

-  • If more than 5" to rain slot you must install another row of shingles.

- 6** Repeat steps 1 - 5 to shingle the opposite side of your roof. Trim shingles at ridge.

- 7** Once both sides are shingled you need to trim ends. Strike a chalk line 1" from edge.

- 8** Using your shingle hooked blade carefully cut shingles along chalk line.

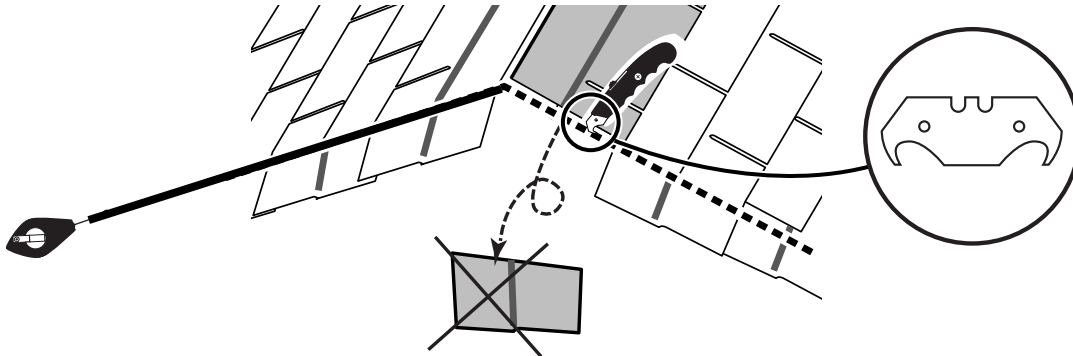

- 9** You have finished shingling your roof. Proceed to capping the ridge.

SHINGLES - RIDGE CAP

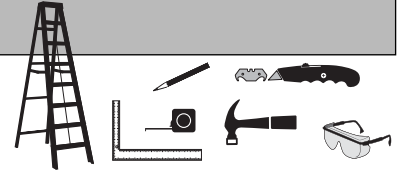

• You will finish off the top of the roof with a ridge cap made from shingles.

BEGIN

1 Cut shingles into THREE pieces. **Hint:** Use cut-off pieces first.

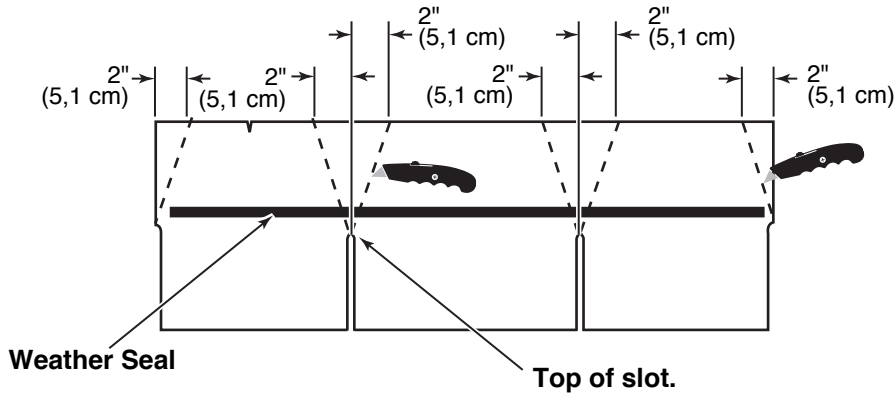

Score shingle, then snap-off angled cut.

Note: • You will need about 20 - 22 cut pieces.

20 to 22 Pieces

2 Install first ridge cap flush to shingles at front, as shown.

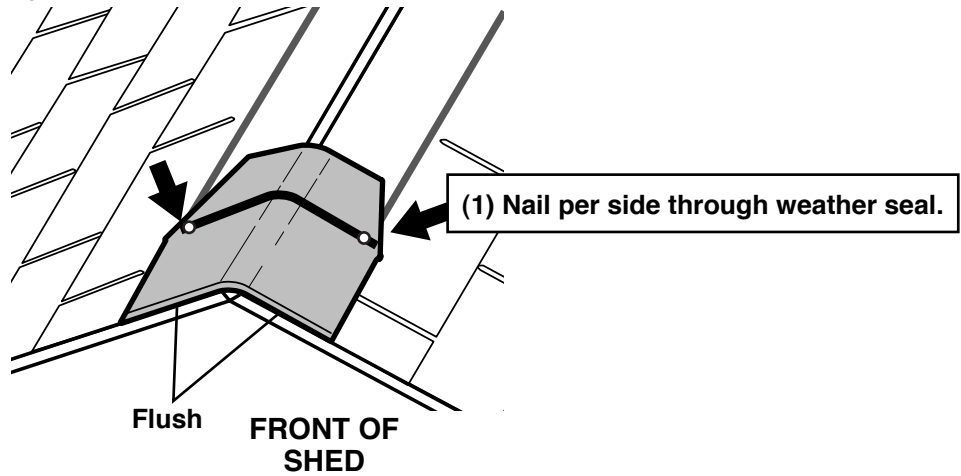

3 Install second ridge cap 5" back, as shown.

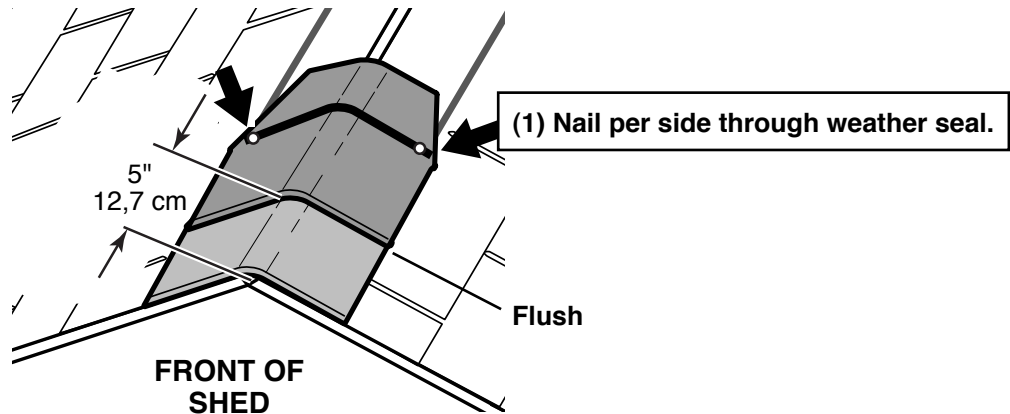

SHINGLES - RIDGE CAP

continued...

- 4 Continue installing ridge cap to back of roof.

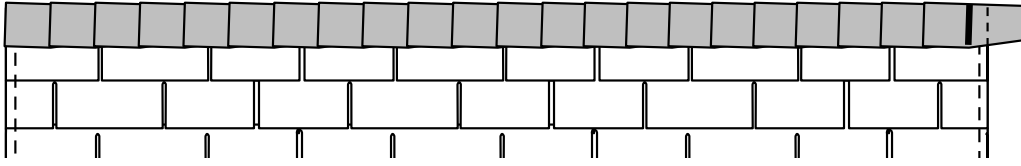

- 5 Make sure there is 4" between the shingle-color and edge of shingles.

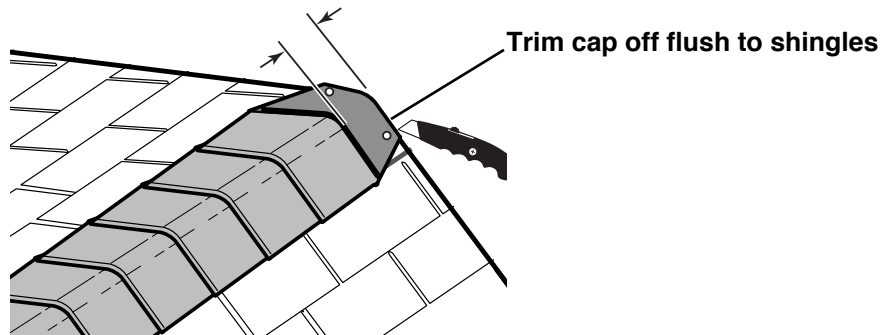

- 6 When you have 4" minimum of shingle color cut one piece to cap your roof.

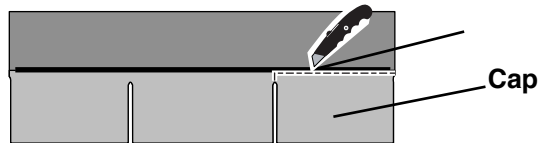

- 7 Install flush to shingles.

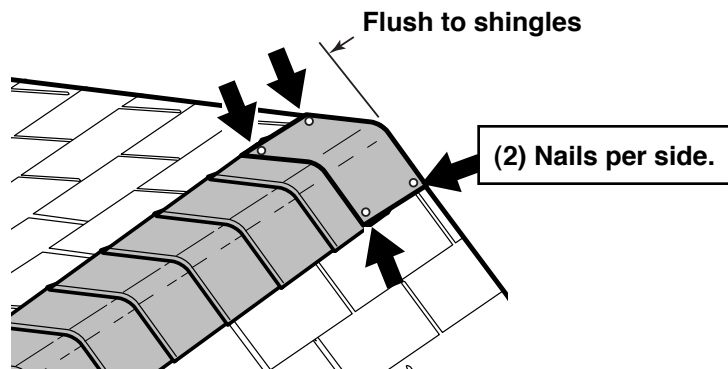

FINISH

- 8 You have finished your ridge cap.

WARRANTY

Backyard Storage Solutions, LLC warrants the following:

1. Every product is warranted from defects in workmanship and manufacturing for one year.
2. All hardware and metal components are warranted for two years.
3. Trim is warranted for 15 years.
4. Waferboard siding and sheathing is warranted for two years.
5. SmartSide™ siding is warranted for 15 years.
6. Timber series buildings' siding and trim are warranted for 10 years.
7. Solar Shed windows are warranted for 1 year.
8. Cedar lumber is warranted for 15 years.
9. Cedar doors and Cedar Garden Center are warranted for 10 years.
10. Metal roof is warranted for 25 years.

**Limited Conditional
Warranty ***

Backyard Storage Solutions, LLC will repair, replace or pay for the affected part. In no event shall Backyard Storage Solutions, LLC pay the cost of labor or installation or any other costs related thereto. All warranties are from date of purchase. If a cash refund is paid on an affected part, it will be prorated from the date of purchase.

CONDITIONS

The warranty is effective only when:

1. The unit has been erected in accordance with the assembly instructions.
2. The unit has been properly shingled and painted or stained and reasonably and regularly maintained thereafter.
3. The failure occurs when the unit is owned by the original purchaser.
4. Backyard Storage Solutions, LLC has received the warranty registration card within thirty (30) days of purchase and notification of the failure in writing within the warranty period specified above.
5. Backyard Storage Solutions, LLC has had reasonable opportunity during the sixty (60) days following receipt of notification to inspect and verify the failure prior to commencement of any repair work.

REQUIREMENTS

Storage Buildings & Playhouses

To validate your warranty, it is necessary to properly maintain your Backyard Storage Solutions, LLC unit; shingle the roof and paint or solid-colored stain the siding using 100% acrylic latex exterior product with a minimum of two (2) coats within thirty (30) days of assembly; caulk above all doors and all horizontal and vertical trim boards; paint and seal all exposed edges, sides and faces of SmartSide™ and waferboard siding to include all exterior walls and all sides and all edges of doors.

Gazebos, Pergolas & Timber Buildings

To validate your warranty, it is necessary to properly maintain your Backyard Storage Solutions, LLC unit. This includes treating all of the exposed cedar and pine surfaces on your gazebo or timber building with an exterior grade wood preservative, an exterior oil-based semi-transparent stain, an acrylic latex exterior paint or an acrylic latex solid color exterior stain within 30 days of assembly and as needed thereafter to maintain your warranty.

Keep vegetation trimmed away from building and make sure siding panels and trim do not come in contact with masonry or cement. The minimum ground clearance for siding must be one half inch (½ inch) from concrete slab or two and one half inches (2 ½") from the ground when building is erected or constructed on a treated wood floor kit. Water from sprinklers must be kept off unit. In no event will Backyard Storage Solutions, LLC be responsible for any indirect, incidental, consequential or special damages nor for failure(s) that are caused by events, acts or omissions beyond our control including, but not limited to, misuse or improper assembly, improper maintenance (which eventually leads to rot or decay) and acts of God. Backyard Storage Solutions, LLC will not be held responsible for any labor costs incurred to construct your unit. This warranty gives you certain specific rights that vary from state to state.

CLAIM PROCEDURE

To make a claim under this warranty, you can either call 1-888-827-9056 or prepare a letter. Please have ready the information below when you call or include the information when writing:

1. The model and size of the product.
2. A list of the part(s) for which the claim is made.
3. Proof of purchase of the Backyard Storage Solutions, LLC item, as shown on the original invoice.
4. Run code, as listed on the yellow warranty card enclosed in the product package.

Mail the above information to:

Backyard Storage Solutions, LLC
Attn: Customer Service
1000 Ternes
Monroe, MI 48162

***WARRANTY TERMS MAY VARY OUTSIDE THE U.S.A.**

IMPORTANT: This is your warranty certificate.

Please complete and mail your warranty card to properly validate your warranty.